



A brand of Asco Pompe
Diaphragm Pumps

Model V5CP Plastic

AIR OPERATED DOUBLE DIAPHRAGM PUMPS

STEPPING UP WITH US

Specifications

Suction & Discharge Size:	1/2" x 1/2"
Standard Porting Location*:	End, Central Horizontal/Vertical
Connection Types:	FBSP
Air Inlet & Air Exhaust Size:	1/4" FNPT x 3/8" FNPT

Capabilities

Maximum Flow Rate:	45,3 lpm
Maximum Air Supply Pressure:	6,9 bar
Displacement per Stroke:	0,14 lit
Minimum Air Inlet Pressure:	0,9 bar
Maximum Particle Size:	2,5 mm
Sound Pressure:	75 dB(A)
Operating Temperature:	Determined by elastomers



V05 Performance

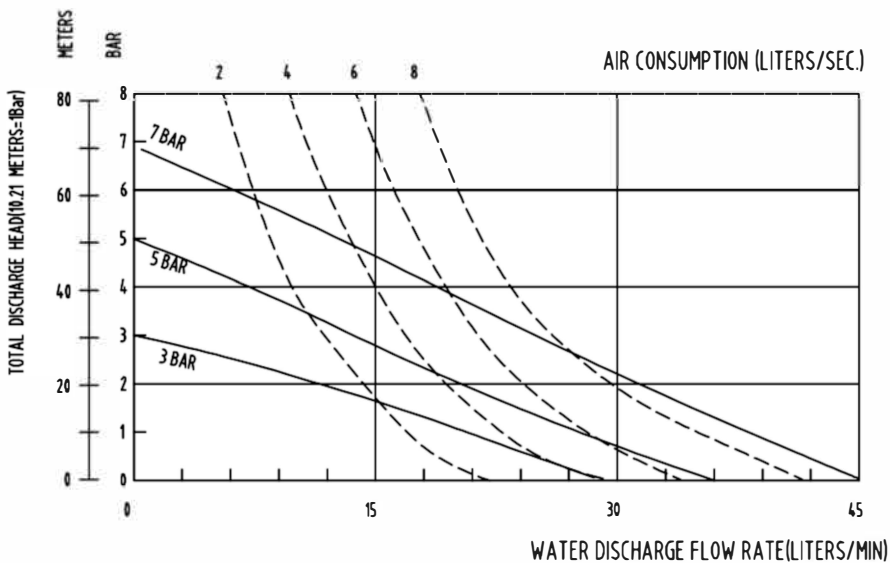

Note: Full stroke diaphragm allows performance to be equal for all elastomers.

Typical Applications

- Acids & Bases
- Plating Solutions
- Paints, Inks, Solvents
- Ceramic Glaze
- Lubricants and Oils

Typical Industries

- Mining
- Paints and Coatings
- Ceramics
- Pulp and Paper
- Electroplating & Anodizing
- Marine
- Chemical Manufacturing & Distribution
- OEM's

Construction

Wetted Materials:	Polypropylene
Diaphragm Materials:	Santoprene™, PTFE
Air Valve:	Polypropylene
Ball materials:	Santoprene™, PTFE
Seat Materials:	Polypropylene
O-ring Materials:	NBR, PTFE

Santoprene™ is a registered tradename of Exxon Mobil Corp.

STEPPING UP WITH US

Dimensions

Maximum Height:	273 mm
Maximum Width:	188 mm
Maximum Depth:	152 mm

Weight

Polypropylene:	2,4 kg
----------------	--------

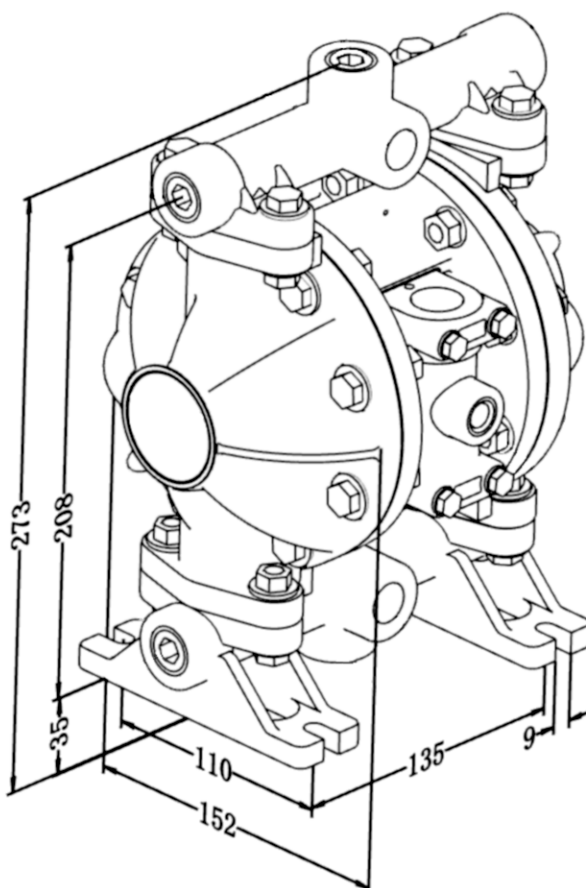

Valisi Diaphragm Pumps - a brand of Asco Pompe

Via Silvio Pellico 6/8 | 20089 ROZZANO (Mi) ITALY

Tel. (+39) 02892571 | Fax (+39) 0289257201

www.valisipumps.com

@: info@valisipumps.com



A brand of Asco Pompe
Diaphragm Pumps