



INSTRUCTION MANUAL

Air operated double diaphragm pumps

Ver. 1.28

Models: DM 08/10

DM 10/25

DM 15/55

DM 25/125

DM 40/315

DM 50/565

DM 80/850

Serial no.

DECLARATION OF CONFORMITY

Directive 2006/42/EC, Annex 2A

Company: **DELLMECO LTD**

Address: **Unit 1, Willow Row
Longton, Stoke on Trent
Staffordshire, ST3 2PU, United Kingdom**

declares under our sole responsibility, that the product:

Product name: **Air Operated Double Diaphragm Pumps**

Models: **DM - series**

Referred to in this declaration conforms with the:

- Directive 2006/42/EC

Date: **July 1st 2014**



**K. Ziemann
Managing Director**

Table of contents

1. Introduction	4
2. For safe operation	4
3. Warnings and cautions	4
4. Operating caution	4
5. Names of parts and materials	6
5.1. DM 08/10, DM 10/25	6
5.2. DM 15/55, DM 25/125	8
5.3. DM 40/315, DM 50/565	10
5.4. DM 80/850	12
6. Assembly	14
7. Installation	14
7.1. Installing the pump	14
7.2. Connecting the ground wire	16
8. Connection	16
8.1. Connecting fluid piping	16
8.2. Connecting air piping	17
9. Operation	18
9.1. Method of operation	18
9.2. Flow adjustment	18
9.3. Shutdown	19
10. Method of cleaning	19
11. Daily check	20
12. Possible problems	20
13. Returning the product for servicing	22
14. Main body specification	24
14.1. Main specification	24
14.2. Appearance and dimensions	24
14.3. Technical Data	25
14.4. Pump code	25
14.5. Performance curves	26
15. Dellmecco Active Pulsation Dampers for Plastic Pumps	27
15.1. Main specification	27
15.2. Appearance and dimensions (pump with pulsation damper)	30
15.3. Discharge port for pulsation damper assembly	30
16. Optional Equipment	31
16.1. Barrier Chamber System (option code BC1, BC2, BC3)	31
16.2. Stroke Counting (option code SC1, SC2, SC3, SC5, SC6)	33
16.3. Diaphragm Monitoring (option code DM1, DM2)	35
16.4. Flange Connections (option code F1, F2, F3, F4, F7, F8, F9)	35
16.5. Sleeve with Split Connections (option code S)	36
16.6. Back Flushing System (option code BF1, BF2, BF4, BF5)	36
16.7. High Pressure System (option code HP)	38
17. Limited warranty	40

1. Introduction

This pump is a positive-displacement pump that transfers fluids by means of diaphragms movement operated by compressed air. The casing in contact with the fluid is made of PE (polyethylene), PE conductive, PTFE (polytetrafluoroethylene), PTFE conductive.

2. For safe operation

This document contains information indispensable for maintaining safe and efficient operation of this product. Read this document carefully before using the pump, particularly the "Warnings and cautions". Get familiar with all operating procedures. This document must be kept handy for future reference.

3. Warnings and cautions

The meanings of warning and caution symbols are given below. Be sure to remember their meanings.



WARNING:

ignoring the warning and operating the product in an improper manner can result in danger of serious bodily injury or death.



CAUTION:

ignoring the warning and operating the product in an improper manner can result in danger of personal injury or property damage.



This symbol means a "DON'T", and will be followed by an explanation on what you must not do.



This symbol means a "DO", and will be followed by an explanation on what you must do in a specified situation.

4. Operating caution

Before using this product



WARNING



To drive the pump you must use one of the following compressed gases (called in this document "compressed air"):

- Compressed air supplied from air compressor
- Nitrogen (N₂) gas

Use of compressed air other than the above may cause air pollution, damage to the pump, or even an explosion.



The maximum permissible pressure for the compressed air, and the fluid pumped by one of its pumps is 8 bars. Should the above applicable maximum permissible pressure be exceeded, the following results may follow: damage to the casing, or even a severe, possibly fatal accident. In some pump executions, specified by manufacturer, the max. pressure can reach 14 bars.



In case a diaphragm gets damaged, fluid will gush out together with air through the exhaust port. Provide protective measures in consideration of possible leakage of fluid. When using the hose and pit etc, make sure to use a model with appropriate corrosion resistance for the fluid to be pumped.



WARNING

- ! When installing this product, be sure to connect a ground wire from the specified position of this product. Otherwise friction between parts and abrasion caused by the flow of some fluids inside the casing may generate static electricity. Depending on the type of fluid being pumped and the installation environment (such as gases in the air and type of surrounding mixtures), static electricity could cause fire or electric shock.
- ! Some fluid may remain inside the pump and inside the connected piping after shutting down the pump, or if the pump is left unused for a prolonged period. Therefore, be sure to purge the system of fluid and clean the pump before prolonged disuse. The fluid remaining in the connected piping as well as the pump itself may expand because of freezing or heat which may cause damage to the pump or/and piping and lead to leakage of the fluid.
- Ø Use only genuine Dellmecc parts when replacing component parts of this product.
- ! Torque of all tightening parts must be checked before running the pump. Designated torques are mentioned in maintenance manual.
- ! In case of pumping a hazardous fluid (hot, flammable, strong acid, etc.) with this pump, protective measures (install a pit, a protection box, sensors, etc.) must be provided in consideration of possible leakage of fluid. Warning signs must be displayed at necessary places. Leakage of fluid may cause fire or accident.
- ! Before using this pump, get fully familiar with the precautions regarding the fluid to be pumped, and verify the corrosion resistance of the parts that will come into contact with the fluid. NEVER use the pump with any fluid against which it does not have sufficient corrosion resistance or with a fluid that poses a risk of explosion. If you are unable to verify the corrosion resistance, contact your dealer. Using this product with any fluid against which the parts in contact with the fluid do not have sufficient corrosion resistance may result in damaging the product or leakage of fluid.



CAUTION

- ! The running pump may generate loud operating noise. Its level will vary depending upon the conditions of use (fluid pumped, supply air pressure and discharge pressure)
- ! To drive this product, supply air with minimum moisture content and without any oil must be used.
- ! If a diaphragm of this pump is damaged, supply air may mix with the fluid or the fluid may flow into the central housing. DO NOT OPERATE THE PUMP if air supply is inadequate or contaminated.
- Ø While operating this product, do NOT put your hand on the inlet port.

5. Names of parts and materials

5.1. DM 08/10, DM 10/25

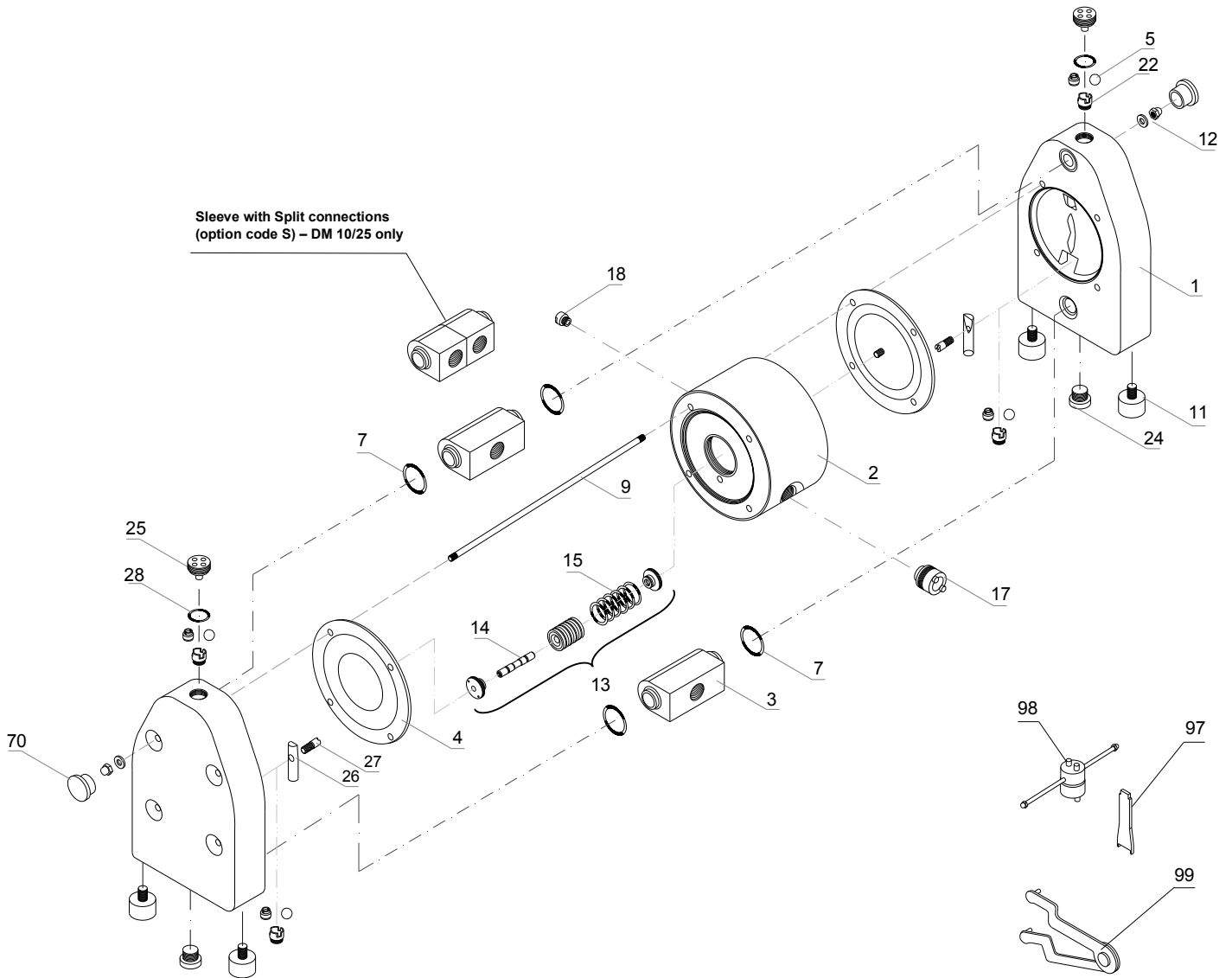

Spare parts list for DM 08/10 and DM 10/25 pumps

				DM 08/10	DM 10/25
1.	2	Pump housing	PE	2 08 01 20	2 10 01 20
			PTFE	2 08 01 23	2 10 01 23
			PE conductive	2 08 01 21	2 10 01 21
			PTFE conductive	2 08 01 24	2 10 01 24
2.	1	Central housing	PE	1 08 10 20	1 10 10 20
			PE conductive	1 08 10 21	1 10 10 21
3.	2	Suction/Discharge ports	PE	2 08 30 20	2 10 30 20
			PTFE	2 08 30 23	2 10 30 23
			PE conductive	2 08 30 21	2 10 30 21
			PTFE conductive	2 08 30 24	2 10 30 24
			AISI 316L	2 08 35 53	2 10 35 53
1	1	Suction port-drum	PE	2 08 33 20	2 10 33 20
			PTFE	2 08 33 23	2 10 33 23
			PE conductive	2 08 33 23	2 10 33 21
			PTFE conductive	2 08 33 24	2 10 33 24
4.	2	Diaphragm	TFM /PTFE	1 08 50 05	1 10 50 05
			EPDM	-	1 10 50 08
			NBR	-	1 10 50 10
			EPDM/TFM/PFA	-	1 10 50 00
5.	4	Cylinder valves	PTFE	2 08 56 23	2 10 56 23
	4	Valve balls	PTFE	1 08 60 23	1 10 60 23
7.	4	Sealing inlet/outlet	EPDM	-	1 10 60 08
			NBR	-	1 10 60 10
			AISI 316	1 08 60 52	1 10 60 52
			Ceramic	-	1 10 60 90
			FEP/FKM	2 08 70 04	2 10 70 04
9.	4	Housing bolt	EPDM	-	2 10 70 08
			NBR	-	2 10 70 10
			AISI 304	2 08 042 50	2 10 042 50
11.	4	Shock absorber	NR/St37	1 08 69 06	1 08 69 06
12.	8	Nut with washer	AISI 304	2 08 045 50	2 10 045 50
13.	1	Air valve	PET/NBR	1 08 020 31	1 08 020 31
			PET/FKM	1 08 020 32	1 08 020 32
14.	1	Shaft	AISI 304	1 08 24 50	1 08 24 50
15.	6	O-ring	NBR	1 08 080 10	1 08 080 10
			FKM	1 08 080 09	1 08 080 09
17.	1	Muffler	PE porous	1 08 99 35	1 08 99 35
18.	1	Air adapter	PP	1 08 46 28	1 08 46 28
19.	1	Handle	AISI 304	-	2 10 98 50
20.	1	Tube	PP	-	1 10 96 28
22.	4	Valve seat	PE	2 08 54 20	2 10 54 20
			PTFE	2 08 54 23	2 10 54 23
			PE conductive	2 08 54 21	2 10 54 21
			PTFE conductive	2 08 54 24	2 10 54 24
24.	2	Plug lower	PE	2 08 59 20	2 10 59 20
			PTFE	2 08 59 23	2 10 59 23
			PE conductive	2 08 59 21	2 10 59 21
			PTFE conductive	2 08 59 24	2 10 59 24
25.	2	Plug upper	PE	2 08 055 20	2 10 055 20
			PTFE	2 08 055 23	2 10 055 23
			PE conductive	2 08 055 21	2 10 055 21
			PTFE conductive	2 08 055 24	2 10 055 24
26.	2	Valve stopper	PE	2 08 39 20	2 10 39 20
			PTFE	2 08 39 23	2 10 39 23
			PE conductive	2 08 39 21	2 10 39 21
			PTFE conductive	2 08 39 24	2 10 39 24
27.	2	Bolt	PE	2 08 38 20	2 10 38 20
			PTFE	2 08 38 23	2 10 38 23
			PE conductive	2 08 38 21	2 10 38 21
			PTFE conductive	2 08 38 24	2 10 38 24
28.	2	Plug upper sealing	FEP/FKM	2 08 78 04	2 10 78 04
			EPDM	-	2 10 78 08
35.	1	Central housing complete	PE	1 08 11 20	1 10 11 20
			PE conductive	1 08 11 21	1 10 11 21
40.	1	DELLMECO nameplate	Diverse	1 08 094 00	1 10 094 00
70.	8	Pump housing plug set	PE	2 08 058 20	2 10 058 20
97.	1	Valve seat key	AISI 304	1 08 254 50	1 10 254 50
98.	1	Upper/lower plug key (SK1,*- SK2)	diverse	1 08 158 00	1 10 158 00*
99.	1	Air valve key (SK4)	diverse	1 08 58 00	1 08 58 00

5.2. DM 15/55, DM 25/125

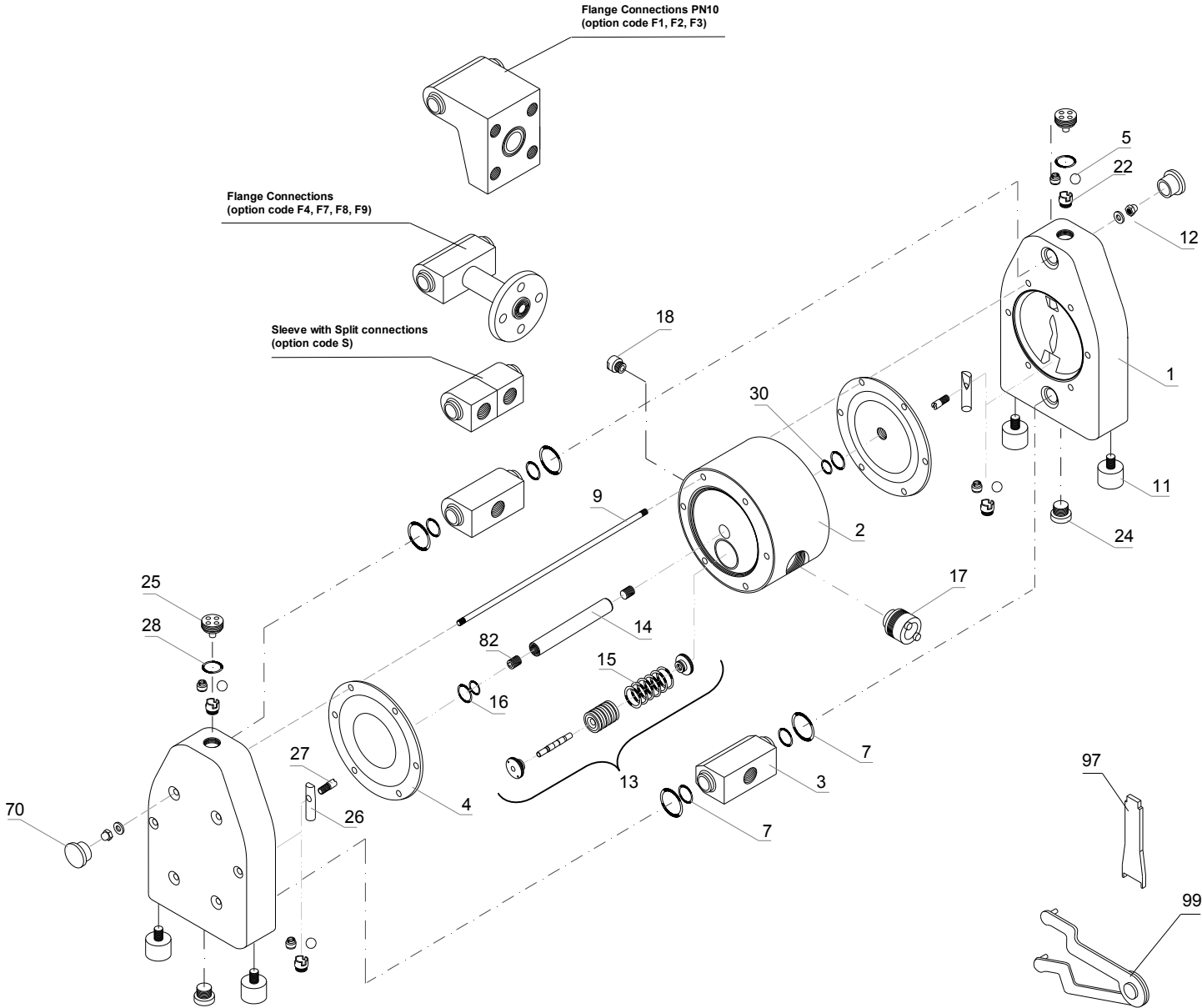

Spare parts list for DM 15/55 and DM 25/125 pumps

				DM 15/55	DM 25/125
1.	2	Pump housing	PE	2 15 01 20	2 25 01 20
			PTFE	2 15 01 23	2 25 01 23
			PE conductive	2 15 01 21	2 25 01 21
			PTFE conductive	2 15 01 24	2 25 01 24
2.	1	Central housing	PE	1 15 10 20	1 25 10 20
			PE conductive	1 15 10 21	1 25 10 21
3.	2	Suction/Discharge ports	PE	2 15 30 20	2 25 30 20
			PTFE	2 15 30 23	2 25 30 23
			PE conductive	2 15 30 21	2 25 30 21
			PTFE conductive	2 15 30 24	2 25 30 24
			AISI 316L	2 15 35 53	2 25 35 53
	1	Suction port-drum	PE	2 15 33 20	2 25 33 20
			PTFE	2 15 33 23	2 25 33 23
			PE conductive	2 15 33 21	2 25 33 21
			PTFE conductive	2 15 33 24	2 25 33 24
			TFM/PTFE	1 15 50 05	1 25 50 05
4.	2	Diaphragm	EPDM	1 15 50 08	1 25 50 08
			NBR	1 15 50 10	1 25 50 10
			EPDM/TFM/PFA	1 15 50 00	-
5.	4	Cylinder valves	PE	2 15 56 20	2 25 56 20
			PTFE	2 15 56 23	2 25 56 23
	4	Valve balls	PTFE	1 15 60 23	1 25 60 23
			EPDM	1 15 60 08	1 25 60 08
			NBR	1 15 60 10	1 25 60 10
			AISI 316	1 15 60 52	1 25 60 52
			Polyurethane	1 15 60 07	1 25 60 07
			Ceramic	1 15 60 90	1 25 60 90
7.	4	Sealing inlet/outlet	FEP/FKM	2 15 70 04	-
			EPDM, EPDM/EPDM*	2 15 70 08	2 25 70 08*
			NBR, NBR/NBR**	2 15 70 10	2 25 70 10**
			PTFE/FKM	-	2 25 73 14
			PTFE/EPDM	-	2 25 73 15
			PTFE-c./FKM	-	2 25 73 16
			PTFE-c./EPDM	-	2 25 73 17
9.	6	Housing bolt	AISI 304	2 15 042 50	2 25 042 50
11.	4	Shock absorber	NR/SI37	1 15 69 06	1 25 69 06
12.	12	Nut with washer	AISI 304	2 15 045 50	2 25 045 50
13.	1	Air valve	PET/NBR	1 15 020 31	1 15 020 31
			PET/FKM	1 15 020 32	1 15 020 32
14.	1	Shaft	AISI 304	1 15 40 50	1 25 40 50
15.	6	O-ring	NBR	1 15 080 10	1 15 080 10
			FKM	1 15 080 09	1 15 080 09
16.	2	Central housing seal	PE	1 15 85 22	1 25 85 22
17.	1	Muffler	PE porous	1 15 99 35	1 15 99 35
18.	1	Air adapter	PP	1 15 46 28	1 15 46 28
19.	1	Handle	AISI 304	3 15 98 50	3 25 98 50
20.	1	Tube	PP	1 15 96 28	1 25 96 28
			PTFE	1 15 96 23	1 25 96 23
22.	4	Valve seat	PE	2 15 54 20	2 25 54 20
			PTFE	2 15 54 23	2 25 54 23
			PE conductive	2 15 54 21	2 25 54 21
			PTFE conductive	2 15 54 24	2 25 54 24
24.	2	Plug lower	PE	2 15 59 20	2 25 59 20
			PTFE	2 15 59 23	2 25 59 23
			PE conductive	2 15 59 21	2 25 59 21
			PTFE conductive	2 15 59 24	2 25 59 24
			PE	2 15 055 20	2 25 055 20
25.	2	Plug upper	PTFE	2 15 055 23	2 25 055 23
			PE conductive	2 15 055 21	2 25 055 21
			PTFE conductive	2 15 055 24	2 25 055 24
			PE	2 15 39 20	2 25 39 20
26.	2	Valve stopper	PTFE	2 15 39 23	2 25 39 23
			PE conductive	2 15 39 21	2 25 39 21
			PTFE conductive	2 15 39 24	2 25 39 24
			PE	2 15 38 20	2 25 38 20
27.	2	Bolt	PTFE	2 15 38 23	2 25 38 23
			PE conductive	2 15 38 21	2 25 38 21
			PTFE conductive	2 15 38 24	2 25 38 24
			FEP/FKM	2 15 78 04	2 25 78 04
28.	2	Plug upper sealing	EPDM	2 15 78 08	2 25 78 08
30.	2/4*	O-ring for central housing seal	NBR	1 15 85 10	1 25 85 10*
35.	1	Central housing complete	PE	1 15 11 20	1 25 11 20
			PE conductive	1 15 11 21	1 25 11 21
40.	1	DELLMECO nameplate	Diverse	1 15 094 00	1 25 094 00
70.	12	Pump housing plug set	PE	2 15 058 20	2 25 058 20
82.	2	Shaft allen pin screw	AISI 304	1 15 540 50	1 25 540 50
97.	1	Valve seat key	AISI 304	1 15 254 50	1 25 254 50
99.	1	Upper/lower plugs and air valve key (SK3, SK4)	diverse	1 08 58 00	1 08 58 00

5.3. DM 40/315, DM 50/565

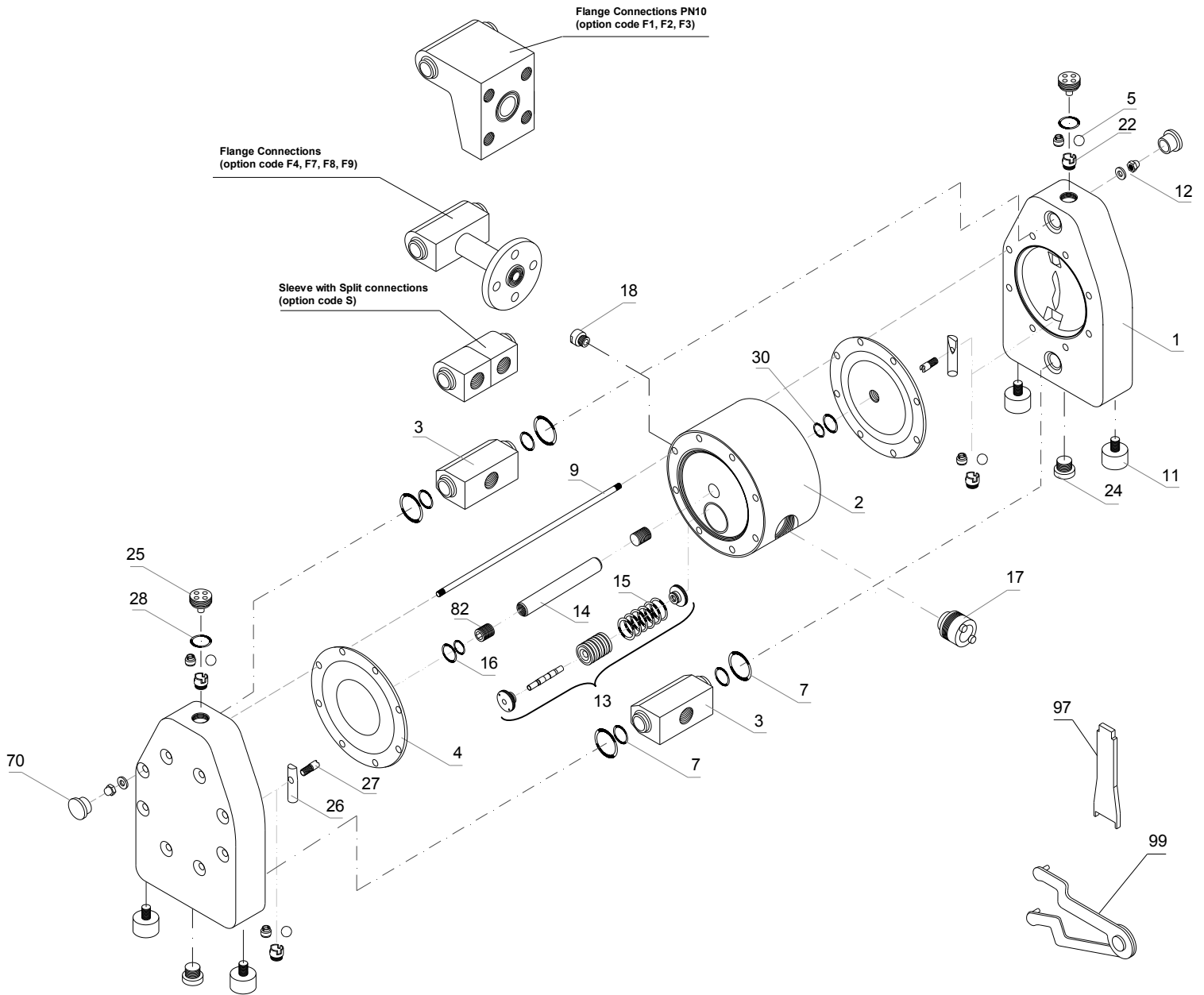

Spare parts list for DM 40/315 and DM 50/565 pumps

				DM 40/315	DM 50/565		
1.	2	Pump housing	PE	2 40 01 20	2 50 01 20		
			PTFE	2 40 01 23	2 50 01 23		
			PE conductive	2 40 01 21	2 50 01 21		
			PTFE conductive	2 40 01 24	2 50 01 24		
2.	1	Central housing	PE	1 40 10 20	1 50 10 20		
			PE conductive	1 40 10 21	1 50 10 21		
3.	2	Suction/Discharge ports	PE	2 40 30 20	2 50 30 20		
			PTFE	2 40 30 23	2 50 30 23		
			PE conductive	2 40 30 21	2 50 30 21		
			PTFE conductive	2 40 30 24	2 50 30 24		
4.	2	Diaphragm	AISI 316L	2 40 35 53	2 50 35 53		
			TFM/PTFE	1 40 50 05	1 50 50 05		
			EPDM	1 40 50 08	1 50 50 08		
			NBR	1 40 50 10	1 50 50 10		
5.	4	Cylinder valves	PE	2 40 56 20	2 50 56 20		
			PTFE	2 40 56 23	2 50 56 23		
7.	4	Valve balls	PTFE	1 40 60 23	1 50 60 23		
			EPDM	1 40 60 08	1 50 60 08		
			NBR	1 40 60 10	1 50 60 10		
			AISI 316	1 40 60 52	1 50 60 52		
			Polyurethane	1 40 60 07	1 50 60 07		
			4	Sealing inlet/outlet - SET	EPDM/EPDM	2 40 70 08	2 50 70 08
					FEP/FKM	2 40 70 04	2 50 70 04
					NBR/NBR	2 40 70 10	2 50 70 10
					PTFE/FKM	2 40 73 14	2 50 73 14
					PTFE/EPDM	2 40 73 15	2 50 73 15
PTFE-c./FKM	2 40 73 16	2 50 73 16					
PTFE-c./EPDM	2 40 73 17	2 50 73 17					
9.	8	Housing bolt	AISI 304	2 40 042 50	2 50 042 50		
11.	4	Shock absorber	NR/SI37	1 40 69 06	1 40 69 06		
12.	16	Nut with washer	AISI 304	2 40 045 50	2 50 045 50		
13.	1	Air valve	PET/NBR	1 40 020 31	1 40 020 31		
			PET/FKM	1 40 020 32	1 40 020 32		
14.	1	Shaft	AISI 304	1 40 40 50	1 50 40 50		
15.	6	O-ring	NBR	1 40 87 10	1 40 87 10		
			FKM	1 40 87 09	1 40 87 09		
16.	2	Central housing seal	PE	1 40 85 22	1 50 85 22		
17.	1	Muffler	PE porous	1 40 99 35	1 50 99 35		
18.	1	Air adapter	PP	1 40 46 28	1 40 46 28		
22.	4	Valve seat	PE	2 40 54 20	2 50 54 20		
			PTFE	2 40 54 23	2 50 54 23		
			PE conductive	2 40 54 21	2 50 54 21		
			PTFE conductive	2 40 54 24	2 50 54 24		
24.	2	Plug lower	PE	2 40 59 20	2 50 59 20		
			PTFE	2 40 59 23	2 50 59 23		
			PE conductive	2 40 59 21	2 50 59 21		
			PTFE conductive	2 40 59 24	2 50 59 24		
25.	2	Plug upper	PE	2 40 055 20	2 50 055 20		
			PTFE	2 40 055 23	2 50 055 23		
			PE conductive	2 40 055 21	2 50 055 21		
			PTFE conductive	2 40 055 24	2 50 055 24		
26.	2	Valve stopper	PE	2 40 39 20	2 50 39 20		
			PTFE	2 40 39 23	2 50 39 23		
			PE conductive	2 40 39 21	2 50 39 21		
			PTFE conductive	2 40 39 24	2 50 39 24		
27.	2	Bolt	PE	2 40 38 20	2 50 38 20		
			PTFE	2 40 38 23	2 50 38 23		
			PE conductive	2 40 38 21	2 50 38 21		
			PTFE conductive	2 40 38 24	2 50 38 24		
28.	2	Plug upper sealing	FEP/FKM	2 40 78 04	2 50 78 04		
			EPDM	2 40 78 08	2 50 78 08		
30.	2	O-ring for central housing seal	NBR	1 40 85 10	1 50 85 10		
35.	1	Central housing complete	PE	1 40 11 20	1 50 11 20		
			PE conductive	1 40 11 21	1 50 11 21		
40.	1	DELLMECO nameplate	Diverse	1 40 094 00	1 50 094 00		
70.	16	Pump housing plug	PE	2 40 058 20	2 50 058 20		
82.	2	Shaft allen pin screw	AISI 304	1 40 540 50	1 50 540 50		
97.	1	Valve seat key	AISI 304	1 40 254 50	1 50 254 50		
99.	1	Upper/lower plugs and air valve key (SK3, SK4)	diverse	1 08 58 00	1 08 58 00		

5.4. DM 80/850

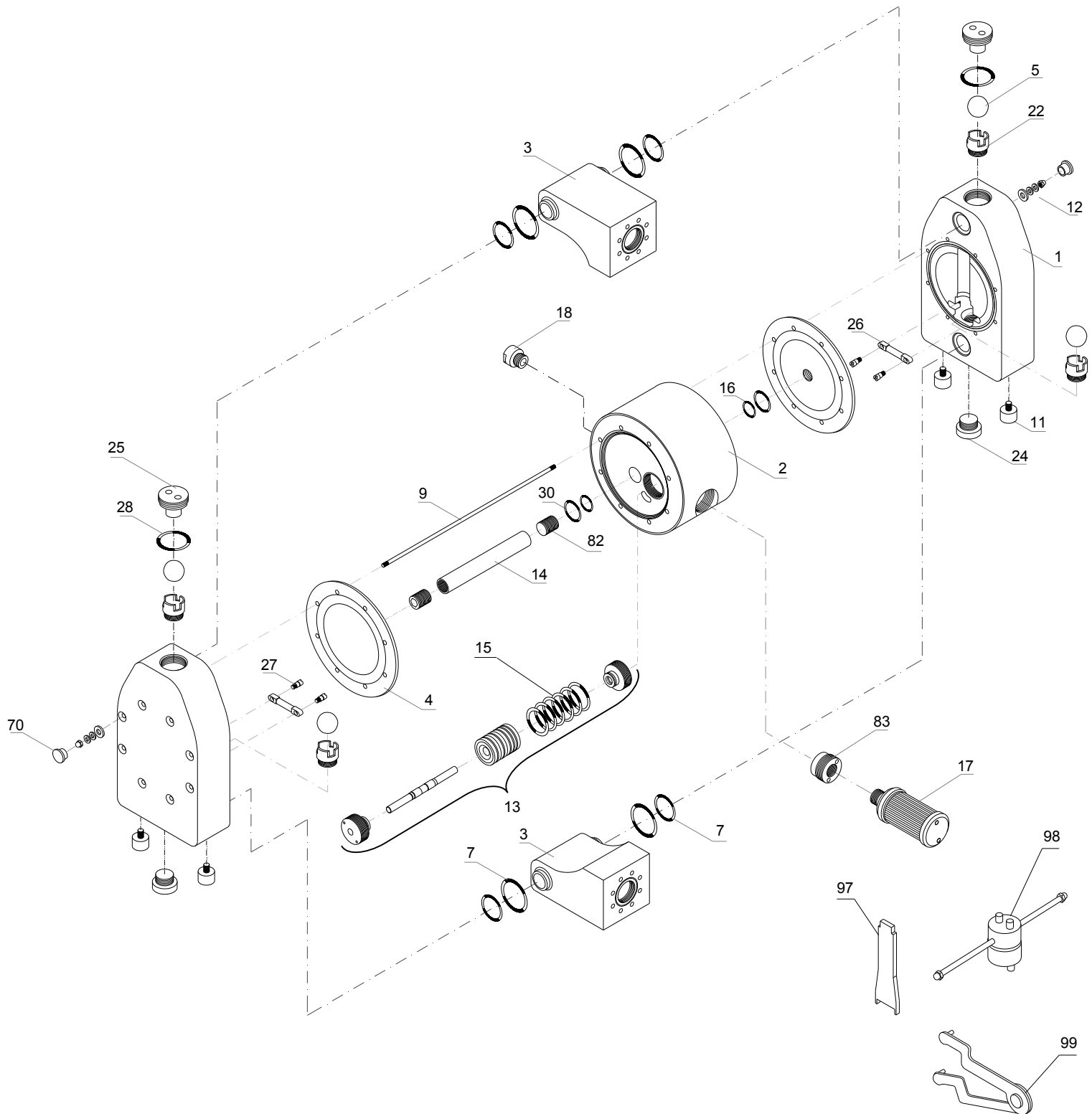

Spare parts list for DM 80/850 pump

				DM 80/850
1.	2	Pump housing	PE	2 80 01 20
			PE conductive	2 80 01 21
2.	1	Central housing	PE	1 80 10 20
			PE conductive	1 80 10 21
3.	1	Suction port	PE	2 80 25 20
			PE conductive	2 80 25 21
1.	1	Discharge port	PE	2 80 025 20
			PE conductive	2 80 025 21
4.	2	Diaphragm	TFM/PTFE	1 80 50 05
			EPDM	1 80 50 08
			NBR	1 80 50 10
5.	4	Valve balls	PTFE	1 80 60 23
			EPDM	1 80 60 08
			NBR	1 80 60 10
7.	4	Sealing inlet/outlet - SET	EPDM/EPDM	2 80 70 08
			FEP-FKM/FKM	2 80 73 14
			FEP-FKM/EPDM	2 80 73 15
			NBR/NBR	2 80 73 10
9.	8	Housing bolt	AISI 304	2 80 042 50
11.	4	Shock absorber	NR/St37	1 80 69 06
12.	16	Nut with washer, cpl.	AISI 304	2 80 045 50
13.	1	Air valve	PET/NBR	1 80 020 31
			PET/FKM	1 80 020 32
14.	1	Shaft	AISI 304	1 80 40 50
15.	6	O-ring	NBR	1 40 87 10
			FKM	1 40 87 09
16.	2	Central housing seal	PE	1 80 85 22
17.	1	Muffler	Diverse	1 80 99 00
18.	1	Air adapter	PP	1 80 46 28
22.	4	Valve seat	PE	2 80 54 20
			PE-conductive	2 80 54 21
24.	2	Plug lower	PE	2 80 59 20
			PE-conductive	2 80 59 21
25.	2	Plug upper	PE	2 80 55 20
			PE conductive	2 80 55 21
26.	2	Valve stopper	PE	2 80 39 20
			PE conductive	2 80 39 21
27.	4	Bolt	PE	2 80 38 20
			PE conductive	2 80 38 21
28.	2	Plug upper sealing	FEP/FKM	2 80 78 04
			EPDM	2 80 78 08
			NBR	2 80 78 10
30.	2	O-ring for central housing seal	NBR	1 80 85 10
35.	1	Central housing complete	PE	1 80 11 20
			PE conductive	1 80 11 21
40.	1	DELLMECO nameplate	Diverse	1 80 094 00
70.	16	Pump housing plug	PE	2 80 058 20
82.	2	Shaft allen pin screw	AISI 304	1 80 540 50
83.	1	Muffler adapter	PE	1 80 299 20
97.	1	Valve seat key	AISI 304	1 80 254 50
98.	1	Upper/lower plugs key (SK5)	diverse	1 80 158 00
99.	1	Air valve key (SK4)	diverse	1 08 58 00

6. Assembly



CAUTION



When installing accessories prevent any foreign matter from getting into the product.
Otherwise malfunction of the air-valve may follow.

7. Installation

7.1. Installing the pump

1) Decide where the pump is to be installed and secure a site.

Note:

- The suction lift should be kept as short as possible.
- Sufficient space around the pump for maintenance must be provided.

When fixing the pump in place, use the cushions on the pump base. The tied-down bolts should be tightened a little at a time to secure the pump.

SELF PRIMING APPLICATION

Suction lift capability may vary depending on the construction materials and application parameters. The range is from 5 meters dry to 9 meters in a primed condition (values calculated for pumping water at 20 degrees Celsius).

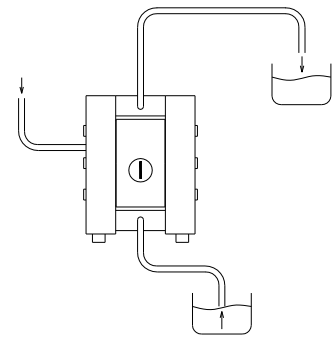

SUBMERGED OPERATION

All pumps may operate in full submersion. Construction materials must be compatible with surrounding liquid and the air exhaust must be placed above the liquid level.

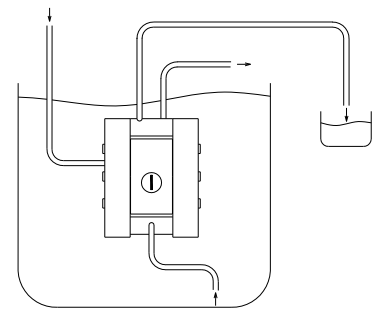

POSITIVE SUCTION HEAD

Common as a method of drawing off the bottoms of holding tanks and clarifiers. Optimum inlet pressure should be kept at 0.2-0.3 bar.

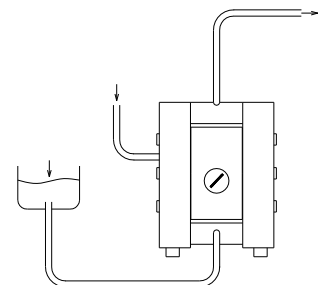



CAUTION

- ! Vibration generated by pump operation should be absorbed. Take it into consideration when mounting it.
- ! When using the pump in submerged position, follow the steps below:
 - Verify the corrosion resistance of each component of the pump. DO NOT expose the pump to any fluid for which it does not have proper corrosion resistance.
 - Exhaust should direct outside, not into the fluid in which the pump is submerged.
- ! The running pump may generate noise. Its level will depend upon conditions of use (kind of fluid being pumped, supply air pressure and discharge pressure).



WARNING

- ! The end of the hose must be equipped with a pit, a protection box, etc. at the end of the hose in case the diaphragm gets damaged and a leakage of the fluid follows.
- ! Pump exhaust should be directed to a safe place, away from people, animals and food.

Size	DM 08/10	DM 10/25	DM 15/55	DM 25/125	DM 40/315	DM 50/565	DM 80/850
Max number of strokes/min. at nominal performance	500	430	240	160	140	100	100



CAUTION

- ! Before putting the pump into operation as well as after some hours of pumping, the housing bolts have to be fixed according to the torque data of the following schedule, as the elements of construction "settle". Both lower and upper plugs [24, 25] have to be fixed, too. Fixing all these parts is necessary as well after longer periods of stoppage, at extreme temperature variations, after transport and dismantling the pump.

Size	DM 08/10	DM 10/25	DM 15/55	DM 25/125	DM 40/315	DM 50/565	DM 80/850
Torque values for housing bolts (Nm): PE pumps	3	6	8	13	17	22	24
PTFE pumps	2	5	7	11	15	19	-

7.2. Connecting the ground wire

- a) When installing the conductive pump, be sure to connect the ground wire at the specified position.
- b) Ground wires should be connected to peripheral equipment and piping as well.
- c) Use 2.0 mm² minimum ground wire.



WARNING



Ground wires must be connected to the piping and any other peripheral equipment. When operating the pump make sure it is properly grounded. Otherwise friction between the parts and abrasion caused by some fluids flowing inside the casing may generate static electricity. In addition it may cause fire or electric shock, depending on the type of fluid being pumped and the installation environment (such as gases in the air or the surrounding mixtures).

8. Connection

8.1. Connecting fluid piping

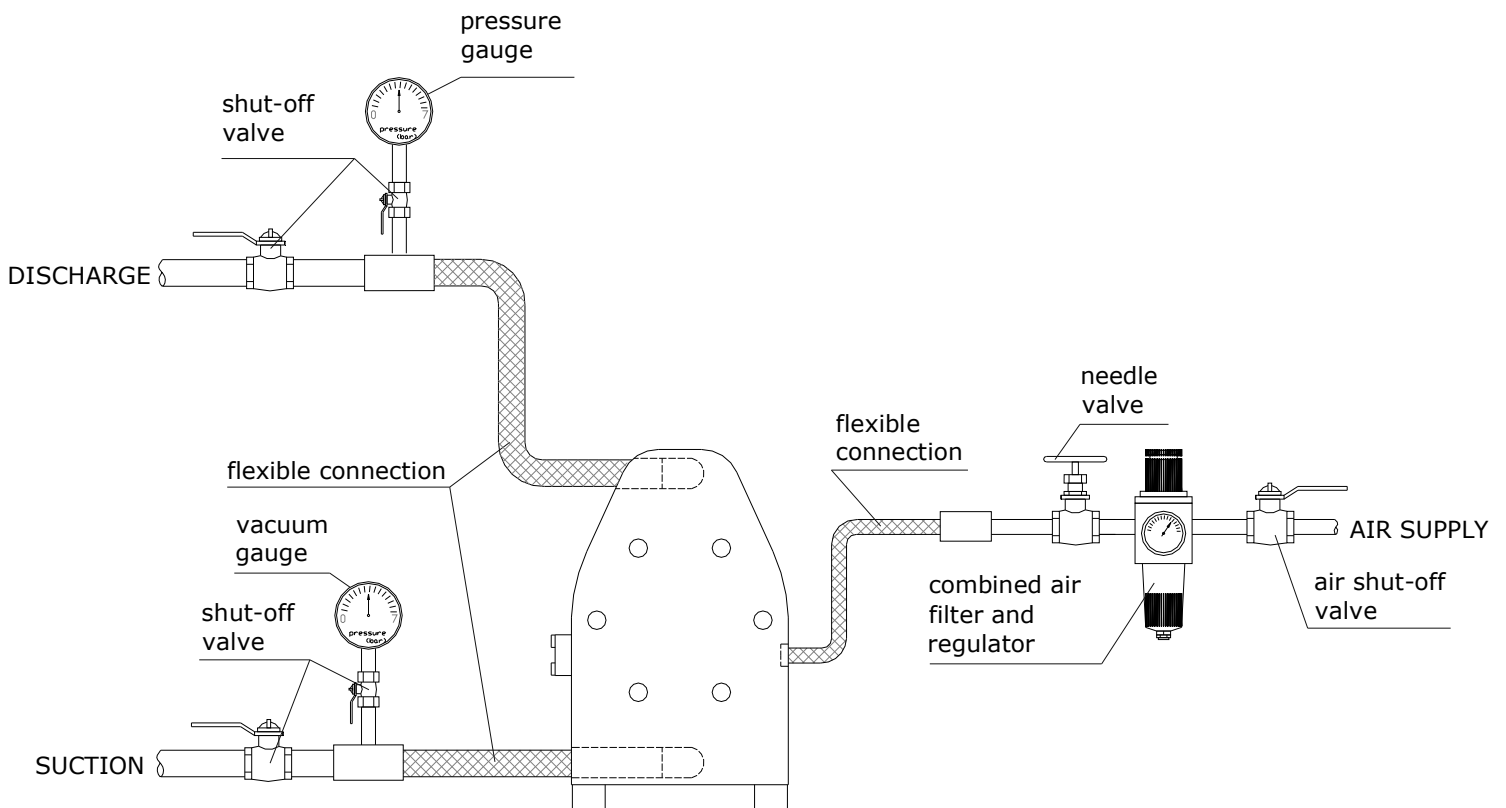

- 1) Connect a flow valve and a drain valve to the fluid discharge port of the pump.
- 2) Connect a valve for maintenance to the fluid suction intake port of the pump.
- 3) Connect a hose to the valve on the suction-port side and the valve of the discharge-port side of the pump.
- 4) Connect a hose on the suction-side intake and the discharge-port side to the respective vessels.



CAUTION

- ! A hose must be flexible to absorb pump vibration. The hose must be grounded.
- ! There must be NO external force on any connection part of the pump. Be especially careful not to have the pump support part of the weight of the hose and the piping.
- ! Use a sturdy hose that will not collapse under the strong suction of the pump. The hose must be of more than sufficient pressure rating.
- ! Use a hose of a diameter the same as or larger than the pump's ports. If the diameter of a hose is smaller, it will affect the pump's performance or cause its malfunction.
- ! Keep a vessel below the relief valve to catch any drain off.
- ! The product has been inspected using clean water at 8 bar discharge pressure.

8.2. Connecting air piping



WARNING

- ! Before starting work, make sure that the air compressor is shut off.

- 1) Connect an air valve, air filter, regulator to a hose connected to the compressor. Install items near the pump.
- 2) Connect the hose from the peripheral equipment to the air valve of the pump's supply port.

Note:

The diameter of the piping should be the same as the diameter of the pump supply port in order to supply sufficient air. Peripheral equipment with sufficient airflow should be chosen to meet the requirement of the pump air consumption. It must be installed nearest the pump unit, even using dry air. Usage and stability of air pressure must be considered.

9. Operation

9.1. Method of operation



CAUTION

- ! Before starting the pump, check that all piping is properly connected.
- ! Before starting the pump, check that **all the bolts are securely tightened**.
- ! Check that the regulator and the drain valve on the discharge side are closed and that the valve on the suction side is opened.

- 1) Start the air compressor.
- 2) Open the air valve. Using a regulator adjust the supply air pressure to within the permissible range.
- 3) Open the flow valve on the discharge side.
- 4) First, check that fluid is flowing inside the piping and is being pumped to the discharge side, and then fully open the air valve.



CAUTION

- ∅ Do NOT open the air valve suddenly.

9.2. Flow adjustment

Adjust the flow valve on the discharge side, or adjust the supply air pressure.



CAUTION

- ! The supply air pressure may initially rise during closing the flow valve. Make sure that the pressure is kept within the normal operating range.
- ! The permissible suction flow speed can vary depending upon the viscosity and specific gravity of the fluid, the suction stroke and other factors. However in case of a rapid growth of the pump speed (flow speed of fluid), cavitations will occur This will reduce pump performance and may cause a malfunction. In order to prevent cavitations, adjust the supply air pressure and the flow.
- ! If fluid is not discharged after you start the pump, or if you hear an abnormal noise or notice any irregularity, shut down the pump immediately.

9.3. Shutdown

Close the air valve of the pump and shut off the supply air.



CAUTION



When the pump is shut down while pumping slurry, particulate matter contained in the slurry will be deposited and get stuck inside the out chamber. Therefore after finishing work the pump must be purged of the remaining fluid. Otherwise when starting the pump again, the diaphragm may get damaged and the centre rod may bend.



CAUTION



Keep a vessel below the relief valve for any drain off.



Be careful! - Fluid under pressure will gush out the moment you open the valve.



If the pump is unused for a prolonged period, purge and clean it.

10. Method of cleaning



WARNING



Make sure that compressed air is not supplied to the pump BEFORE you start cleaning the pump.



Make sure that the pump is not pressurized BEFORE you start cleaning the pump.

- 1) Remove the hose from the suction side of the pump.
- 2) Close the flow valve on the discharge side and open the drain valve. Then start air pressure for a while to discharge possibly much fluid remaining inside the pump.
- 3) Remove the hose from the discharge side, and attach different hoses to the suction side and the discharge side for cleaning.
- 4) Be ready with a vessel with cleaning solution, the kind appropriate for the type of fluid pumped. Next connect the suction-side and the discharge-side hoses of the pump.
- 5) Start the pump air pressure slowly, and let the cleaning solution circulate for sufficient cleaning.
- 6) Flush with clean water.
- 7) Remove the hose from the suction side of the pump, run the pump for a while to purge the pump of remaining fluid as much as possible.



CAUTION



Be extremely careful when removing piping - the fluid will gush out.



After cleaning with clean water, turn the pump upside-down to let the water flow out.

11. Daily check

Before starting pump operation, conduct the following check procedures every day. In case there appears any irregularity, do NOT start running the pump until the cause of the irregularity has been determined and corrective measures have been taken.

- a) Make sure that there is no leakage of fluid from any connection part or the pump.
- b) Make sure that there are no cracks in the pump casing or piping.
- c) Check the tightness of every bolt of the pump.
- d) Make sure that the connection parts of the piping and peripheral equipment are not loose.
- e) Make sure that any parts of the pump that are to be replaced at regular intervals have been changed.

12. Possible problems

12.1. Pump does not run

Cause	Action to take
The exhaust port (muffler) of pump is clogged with sludge.	Check and clean the exhaust port and muffler.
Air is not supplied.	Start the compressor, and open the air valve and air regulator.
The supply air pressure is low.	Check the compressor and the configuration of air piping.
Air leaks from connection parts.	Check the connection parts and tightness of bolts.
The flow valve on the discharge side is not open.	Open the flow valve on the discharge side.
The fluid piping is clogged with sludge.	Check and clean the fluid piping.
The pump is clogged with sludge.	Disassemble the casing, check and clean.

12.2. Pump runs, but fluid does not come out

Cause	Action to take
The suction lift or discharge head is long.	Confirm the piping configuration and shorten the length.
The discharge-side fluid piping (including the strainer) is clogged with sludge.	Check and clean the fluid piping.
The valve on the suction side is not open.	Open the valve on the suction side.
The pump is clogged with sludge.	Disassemble the casing, check and clean.
The balls and valve seats are worn out or damaged.	Disassemble the pump, check and replace parts.

12.3. Flow (discharge volume) decreased

Cause	Action to take
The supply air pressure is low.	Check the compressor and configuration of air piping.
Air piping or peripheral equipment is clogged with sludge.	Check and clean the air piping.
The discharge-side flow valve opens differently.	Adjust the discharge-side flow valve.
Air is taken in together with fluid.	Replenish fluid and check the configuration of the suction-side piping.
Cavitations occur.	Adjust the supply air pressure and discharge pressure, and shorten the suction lift.
Chattering occurs.	Adjust the supply air pressure and discharge pressure. Reduce inlet flow valve to adjusting liquid pressure and volume.
The fluid piping (including the strainer) is clogged with sludge.	Check and clean the fluid piping and strainer.
The exhaust port (muffler) of the pump is clogged with sludge.	Check and clean the exhaust port and muffler.
The pump is clogged with sludge.	Disassemble the casing, check and clean.

12.4. Liquid leakage from exhaust port (silencer)

Cause	Action to take
Damaged diaphragms.	Replace the diaphragms.

12.5. High air consumption during operation

Cause	Action to take
The o-rings and sleeves are worn out.	Disassemble the air-valve, check and clean. Replace parts as necessary.

12.6. Irregular noise

Cause	Action to take
The supply air pressure too high.	Adjust the supply air pressure.
The pump is clogged with sludge with particles of larger than the permissible diameter.	Disassemble the casing, check and clean.

12.7. Irregular vibration

Cause	Action to take
The supply air pressure too high.	Adjust the supply air pressure.
The sleeves are worn out.	Disassemble the air-valve, check and clean. Replace parts as necessary.
Connection parts and pump mounting are loose.	Check each connection part and tighten the bolts.

If any of the above mentioned causes do not apply to your problem, contact your dealer or our office.

13. Returning the product for servicing

If you want to return the product for servicing, copy the **Trouble-Reporting FAX Sheet**, fill it out giving the details of the problem and conditions of operation, and fax it to your dealer or our regional office.

- 1) Get an acceptance from your dealer or regional office.
- 2) Clean the pump.
- 3) Return the product in the same package as when it was first shipped from the factory.

Trouble-Reporting FAX Sheet

Your information will be most helpful in our efforts to improve our service as well as checking into causes of troubles and irregularities. We kindly request you therefore to fill out the following FAX sheet carefully and fax it to your dealer or our regional office. Thank you.

Company		Name of person in charge	
Address	Department		
	Telephone		
	Fax	e- mail	
MODEL		Year of manufacturing	
Period of use		Serial No.	
Operating conditions *Indoor * Outdoor		Date of Purchase	
Frequency of operation * Continuous * Intermittent _____ Hours/day/week/month		Name of Dealer _____	
Operating air pressure _____ bar Discharge pressure _____ bar Discharge volume _____ l/min. Suction side _____ m Suction side diameter _____ m Discharge side _____ m		Type of fluid pumped _____ Specific gravity _____ Viscosity _____ cPs Fluid temperature _____ *C/*F Slurry: *YES Density _____ wt% Particulate diameter _____ mm *NO	
Problem			
Draw a summary drawing of application (size, length of piping, and component parts)			



WARNING



It is the end-user responsibility to thoroughly wash and clean the pump to prevent any damages caused by accidental liquid leaks.



CAUTION



Be sure to maintain the transport safety by preventing any liquid leaks from the pump.

14. Main body specification

14.1. Main specification



CAUTION



Due to constant improvements and/or modifications to our products, the dimensions and detailed technical specifications may be changed without prior information. Any claims concerning these changes shall not be considered. Please contact your dealer or our regional office for details.

14.2. Appearance and dimensions

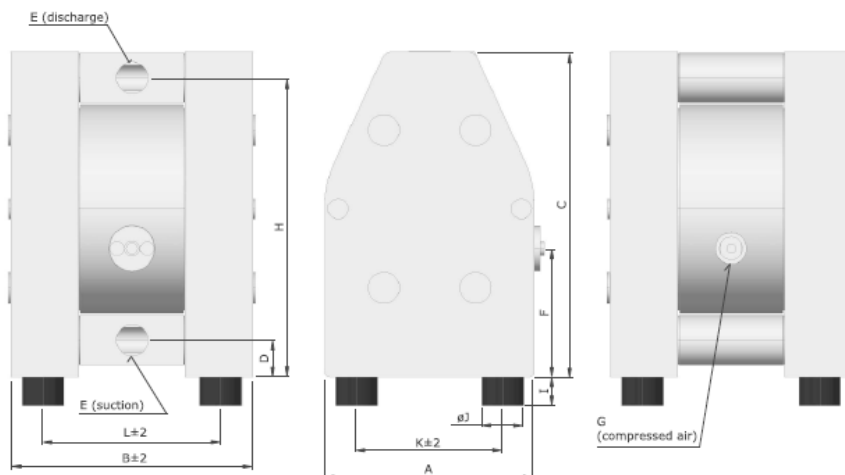

	A	B	C	D	E	F	G	H	I	ØJ	K	L
DM 08/10	70	113	120	15	G 1/4"	58	R 1/8"	107	10	15	50	86
DM 10/25	105	128	164	18	G 3/8"	84	R 1/8"	150	10	15	75	93
DM 15/55	153	177	235	25	G 1/2"	87	R 1/4"	217	18	30	112	136
DM 25/125	200	232	312	35	G 1"	123	R 1/4"	287	28	40	140	170
DM 40/315	270	312	426	42	G 1 1/2"	109	R 1/2"	388	30	60	190	227
DM 50/565	350	385	540	45	G 2"	158	R 1/2"	485	30	60	270	282
DM 80/850	480	580	800	100	G 3"	388	R 3/4"	690	40	75	395	495

14.3. Technical Data

Pump size	08/10	10/25	15/55	25/125	40/315	50/565	80/850
Max capacity (l/min)	10	25	55	125	315	565	850
Max pressure (bar)	8						
Nominal port size	G 1/4"	G 3/8"	G 1/2"	G 1"	G 1 1/2"	G 2"	G 3"
Air connection	R 1/8"	R 1/8"	R 1/4"	R 1/4"	R 1/2"	R 1/2"	R 3/4"
Suction lift dry (mWC):	0.5 / 1.5*	2.0	3.0	4.0	4.0	5.0	5.0
Suction lift wet (mWC)	9.0						
Max diameter solids (mm)	2	3	4	7	10	12	15
Temperature limits - PE (°C)	70	70	70	70	70	70	70
Temperature limits - PTFE (°C)	110	110	120	120	120	120	-
Weight - PE (kg)	0.9	1.6	4.2	9.7	23.8	45.0	170
Weight - PTFE (kg)	1.5	2.4	6.8	16.5	44.5	87.0	-
Material of pump housing	PE, PE-cond., PTFE, PTFE-cond.						PE, PE-cond.
Diaphragm options	TFM/PTFE	EPDM, NBR, TFM/PTFE					
Valve balls	PTFE, AISI 316	EPDM, NBR, TFM/PTFE, AISI 316, PU				EPDM, NBR, TFM/PTFE	
Cylinder valves	PTFE	PE, PTFE					-
O-rings	EPDM, NBR, FEP/FKM, PTFE+EPDM, PTFE-cond. +EPDM, PTFE+FKM, PTFE-cond.+ FKM						

* - suction lift dry 0.5 m for ball valves and 1.5 m for cylinder valves

14.4. Pump code

DM 15/55 PTS-DM 1	DM 1 - Optional equipment:
<p>DM - Dellmeeco Pump</p> <p>15 - Port dimension, DN</p> <p>55 - Max capacity l/min at 8 bar</p> <p>P - Housing material:</p> <p>P - PE</p> <p>R - PE conductive</p> <p>T - PTFE</p> <p>Z - PTFE conductive</p> <p>T - Diaphragm material:</p> <p>E - EPDM</p> <p>N - NBR</p> <p>T - TFM/PTFE</p> <p>S - Material and kind of valve:</p> <p>E - EPDM, ball valve</p> <p>N - NBR, ball valve</p> <p>S - AISI 316, ball valve</p> <p>T - PTFE, ball valve</p> <p>U - Polyurethane, ball valve</p> <p>F - PTFE, cylinder valve</p> <p>P - PE, cylinder valve</p> <p>C - Ceramic, ball valve</p>	<p>BC1 – Barrier Chamber with sensors (NAMUR)</p> <p>BC2 – Barrier Chamber as BC1 with controllers</p> <p>BC3 – Barrier Chamber as BC2, ATEX</p> <p>DM1 – Diaphragm Monitoring, NAMUR – ATEX</p> <p>DM2 – Diaphragm Monitoring with controller</p> <p>F1 – Flange Connection PN10 with EPDM O-ring</p> <p>F2 – Flange Connection PN10 with NBR O-ring</p> <p>F3 – Flange Connection PN10 with FEP/FKM O-ring</p> <p>F4 – Flange Connection JIS 5K</p> <p>F7 – Flange Connection PN10 DIN 2576</p> <p>F8 – Flange Connection ANSI 150 RF-SO</p> <p>F9 – Flange Connection PN16 DIN 2277/2278</p> <p>NPT – NPT Thread Connection</p> <p>SC1 – Stroke sensor, ATEX</p> <p>SC2 – SC1 plus stroke counter</p> <p>SC3 – SC1 plus stroke counter – ATEX</p> <p>SC5 – Stroke counting pneumatical with pressure transmitter</p> <p>SC6 – SC5 plus stroke counter</p> <p>BF1 – Back flushing system, hand operated, EPDM seals</p> <p>BF2 – Back flushing system, hand operated, FEP/FKM seals</p> <p>BF4 – Back flushing system, pneumatical, EPDM seals</p> <p>BF5 – Back flushing system, pneumatical, FEP/FKM seals</p> <p>AF1, AF2 - Air filter, regulator, valve, nipple, connector</p> <p>D – Drum pump</p> <p>HP – High pressure</p> <p>MV – Pump with solenoid valve</p> <p>S – Sleeve with split connections</p> <p>P – Powder pump</p> <p>T – Trolley</p> <p>CLEAN – The clean package to meet enlarged purity requirements for special pump applications</p>

14.5. Performance curves

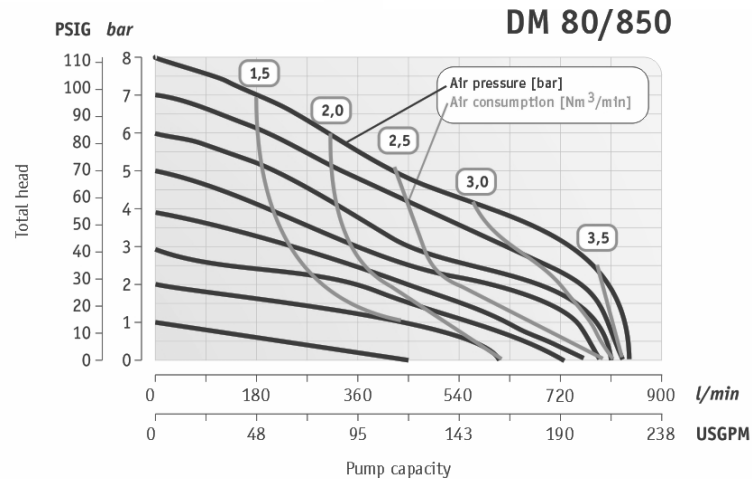
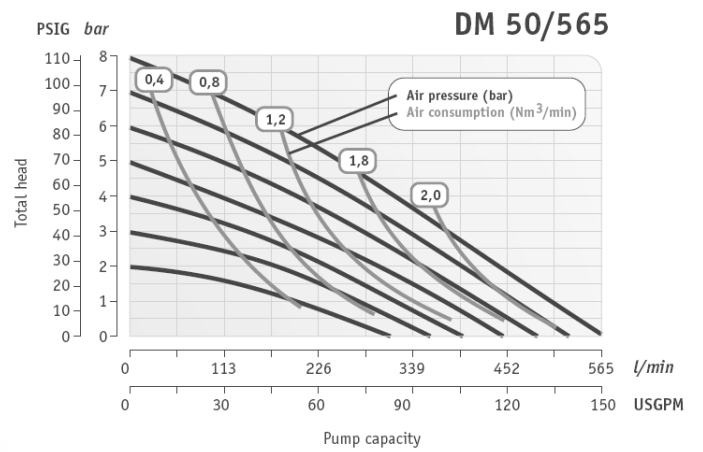
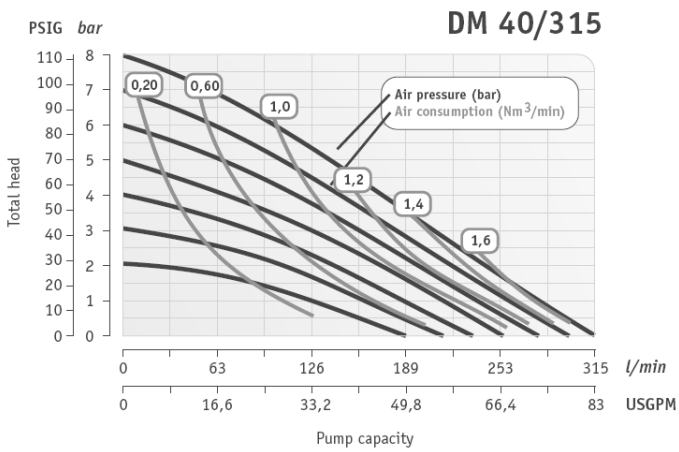
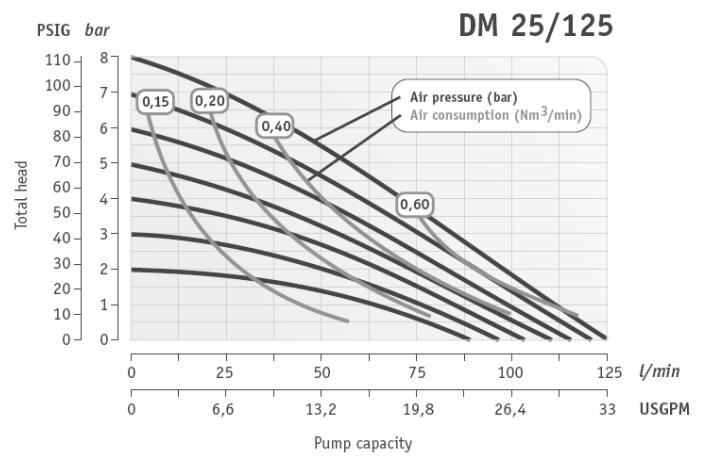
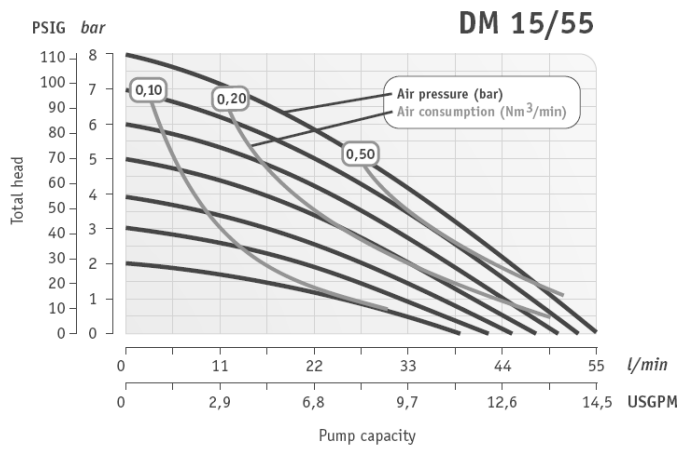
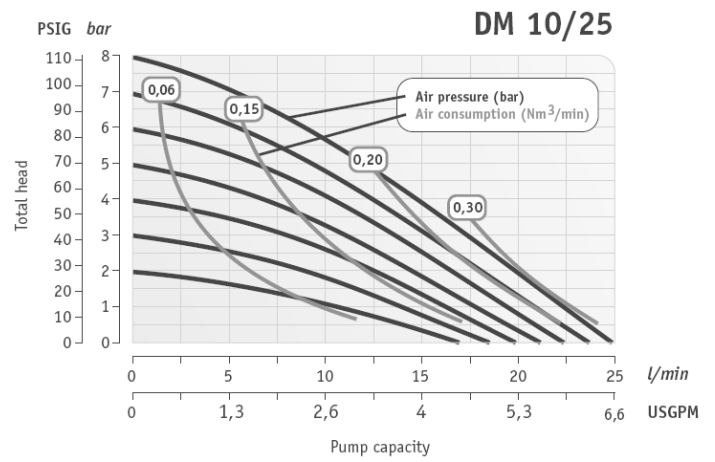
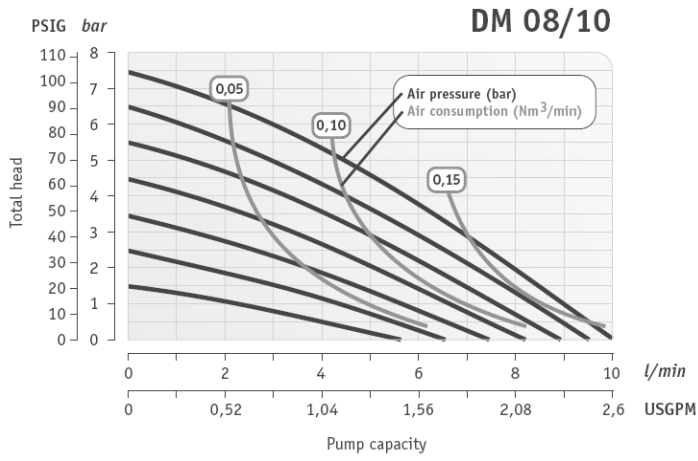

15. Dellmecco Active Pulsation Dampers for Plastic Pumps

15.1. Main specification

The Dellmecco active pulsation dampers represent the latest generation of active pulsation dampers. They are specially designed to be used along with DELLMECO pneumatic double diaphragm pumps of the Plastic range. A general aspect to be considered is, that a pulsation damper decreases the total capacity of the system depending on the point of operation.

Before putting a DELLMECO pulsation damper into operation, make sure, that the materials of construction are resistant to the chemical to be pumped. To check this, the exact damper code is required. This code, as well as the serial number, can be found in the following. Besides, these data are noted on the identification plates on the damper itself.

Example of the damper type code:

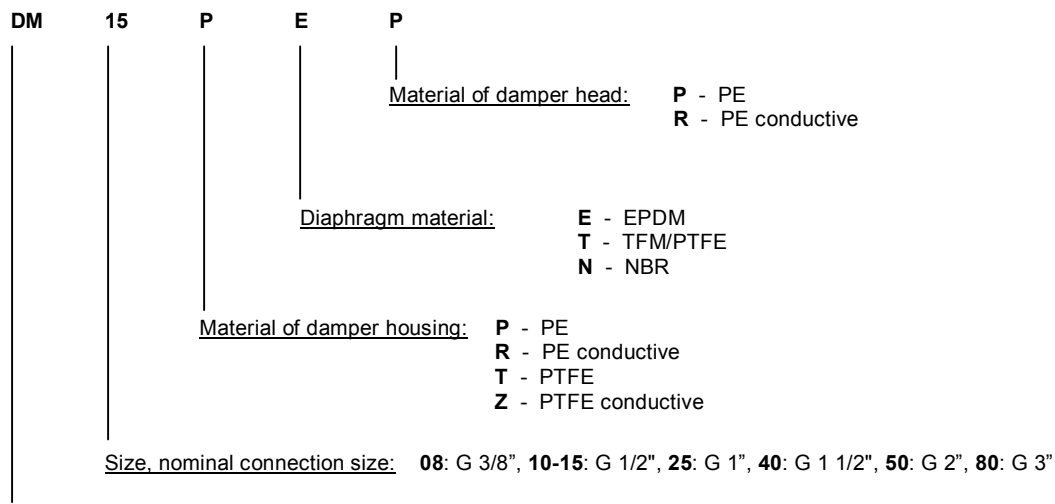

DELLMECO pulsation damper.

Air supply connection: DM 08-25: R 1/8", DM 40-50: R 1/4", DM 80: R 3/4"

Max. operating pressure: 8 bar

Max. operating temperature: for damper housing in PE 70°C,
for damper housing in PTFE size DM 08, DM 10 100°C,
for the other sizes 120°C (with damper head in PE conductive 80°C)

For inflammable liquids as well as for applications in explosion protected areas, only dampers made of conductive polymer materials (codes R and Z) may be used. It is not necessary to ground the damper separately, as the damper is connected conductively to the pump, which is conductive and has to be grounded itself.

In general, pump and damper are dispatched completely mounted. Still, they can be packed in separate boxes, for client's wish. If so, the damper has to be screwed into the thread at the top of discharge port carefully, but only until the damper is in contact with the pump. Exceeded tightening may damage the thread. Besides, a correct positioning of the O-ring [45] within the groove has to be ensured.

The DELLMECO damper can easily be attached to a pump at any time in the future by changing the discharge port. The use of a pulsation damper of the series DM reduces the capacity of the complete system in dependence of the point of operation.

Before connecting the pump, take the yellow blind plugs out of air inlet which is located on the top of the damper head [41]. For correct operation, the damper absolutely needs an air-supply of its own, which has to be taken from the air-supply of the pump. Pump and pulsation damper have to be connected to the same air pressure. No stop or regulating valve may be placed between pump and damper. The driving air has to be oil-free, dry and clean. Together with the pump an empty damper has to be driven slowly. The dampers are self-regulating for all changing operating conditions.

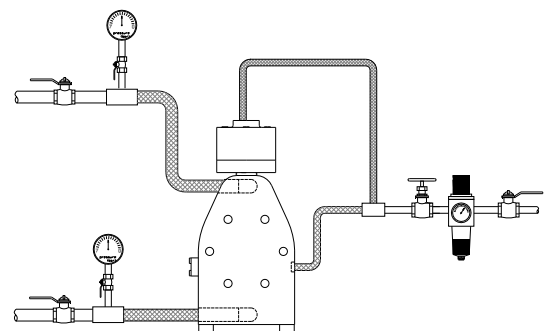



CAUTION

- ! Before putting the pulsation damper into operation as well as after some hours of operating, the housing bolts [42] have to be tightened carefully, as the elements of construction tend to "settle". Fixing the bolts is necessary as well after longer periods of stoppage, at extreme temperature variations, transport and after dismantling.
- ! Pressure tests of the plant, the pump and the damper are included and may only be carried out with the aggregate (pump and damper) disconnected from the pressure on both ports or by using the pressure the aggregate develops while operating. The load of a pressure in the plant may damage the pump and the pulsation damper.
- ! Before starting to disassemble the pump, take care that pump and damper have been emptied and rinsed. Further, both have to be cut off from any energy on the air and product side. If pump and damper is being deported from the plant, a reference about the delivered liquid has to be attached.
- ! Please respect the relevant additional security advices, if the pump and the damper have been used for aggressive, dangerous or toxic liquids.
- ! Before putting the pump and the damper back into operation, the tightness of both has to be checked.

Disassembly instructions

Unscrew housing bolts [42] carefully. After that, all parts can be removed. Screw the diaphragm [40] off the actuator shaft [39]. A re-assembly of used piston rings [37] is impossible; they have to be replaced including the O-rings underneath. To assemble new piston rings [37] carefully shape them like kidneys with locking ring pliers and insert the rings into the grooves; completely press the rings into the grooves smoothly using some round tool.

Spare part list, pulsation damper series

Damper size:				DM 08	DM 10	DM 15	DM 25	DM 40	DM 50	DM 80
Pos.	Quantity	Description	Material	Part no.	Part no.	Part no.	Part no.	Part no.	Part no.	Part no.
36.	1	Damper housing	PE	8 08 001 20	8 10 001 20	8 15 001 20	8 25 001 20	8 40 001 20	8 50 001 20	8 80 001 20
			PTFE	8 08 001 23	8 10 001 23	8 15 001 23	8 25 001 23	8 40 001 23	8 50 001 23	-
			PE conductive	8 08 001 21	8 10 001 21	8 15 001 21	8 25 001 21	8 40 001 21	8 50 001 21	8 80 001 21
			PTFE conductive	8 08 001 24	8 10 001 24	8 15 001 24	8 25 001 24	8 40 001 24	8 50 001 24	-
37.	3	Piston ring	PE	1 08 90 22	1 08 90 22	1 08 90 22	1 15 85 22	1 25 85 22	1 40 85 22	1 80 85 22
38.	3	O-ring	NBR	1 08 82 10	1 08 82 10	1 08 82 10	1 15 85 10	1 25 85 10	1 40 85 10	1 80 85 10
39.	1	Actuator shaft	PET, AISI 304*	8 08 40 30	8 08 40 30	8 08 40 30	8 25 40 30	8 40 40 50*	8 50 40 50*	8 80 40 50*
40.	1	Diaphragm	EPDM	-	1 10 50 08	1 10 50 08	1 15 50 08	1 25 50 08	1 40 50 08	1 50 50 08
			TFM / PTFE	1 08 50 05	1 10 50 05	1 10 50 05	1 15 50 05	1 25 50 05	1 40 50 05	1 50 50 05
			NBR	-	1 10 50 10	1 10 50 10	1 15 50 10	1 25 50 10	1 40 50 10	1 50 50 10
			EPDM/TFM/PFA	-	1 10 50 00	1 10 50 00	1 15 50 00	-	-	-
41.	1	Damper head	PE	8 08 203 20	8 10 203 20	8 10 203 20	8 25 203 20	8 40 203 20	8 50 203 20	8 80 203 20
			PE conductive	8 08 203 21	8 10 203 21	8 10 203 21	8 25 203 21	8 40 203 21	8 50 203 21	8 80 203 21
42.	4/ 6** / 8***	Housing bolt	AISI 304	8 08 542 50	8 10 542 50	8 10 542 50	8 25 542 50**	8 40 542 50**	8 50 542 50***	8 80 542 50***
43.	8/ 12** / 16***	Nut with washer (covered)	AISI 304	1 08 145 50	1 10 145 50	1 10 145 50	1 25 145 50**	1 40 145 50**	1 50 145 50***	1 80 145 50***
44.	1	Muffler	PE	8 08 99 20	8 08 99 20	8 08 99 20	8 25 99 20	8 40 99 20	8 50 99 20	8 80 99 20
45.	1	Damper housing O-ring	FEP/FKM	8 08 79 04	2 15 70 04	2 15 70 04	3 25 70 04	8 40 79 04	2 40 78 04	2 80 78 04
			EPDM	8 08 79 08	2 15 70 08	2 15 70 08	3 25 70 08	8 40 79 08	2 40 78 08	2 80 78 08
46.	8/ 12** / 16***	Housing bolt plug	PE	8 08 058 20	8 10 058 20	8 10 058 20	8 25 058 20**	8 40 058 20**	8 50 058 20***	8 80 058 20***

PULSATION DAMPER – exploded view

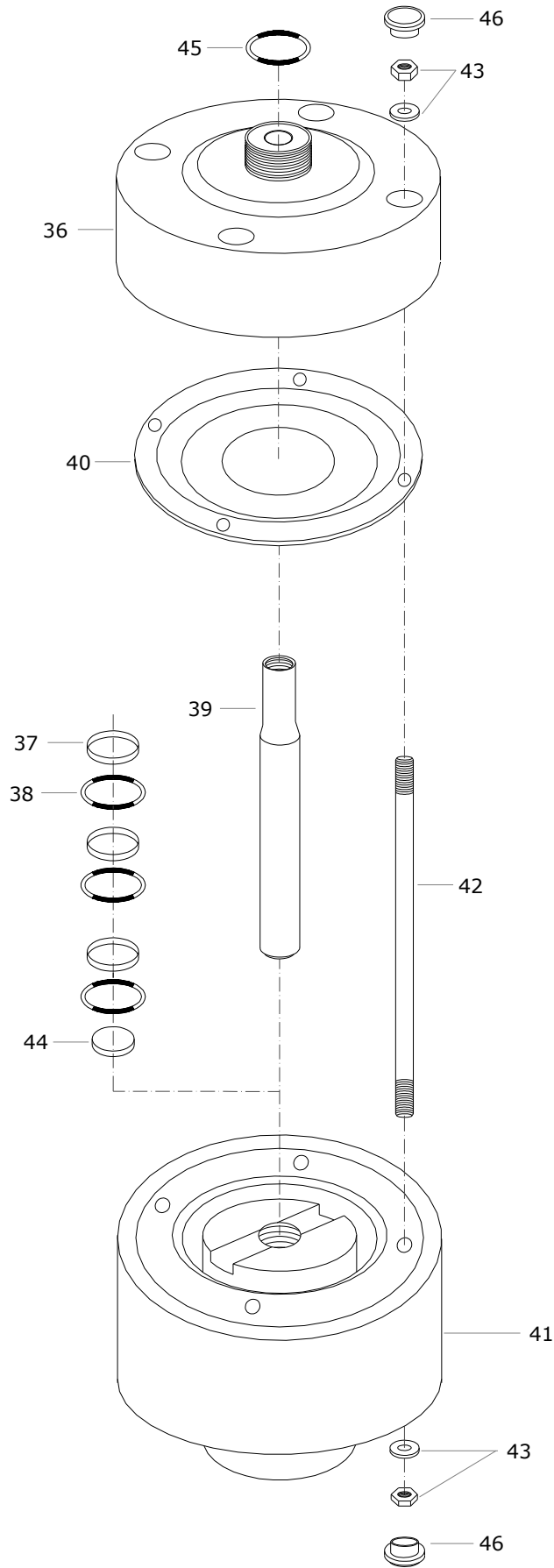

15.2. Appearance and dimensions (pump with pulsation damper)

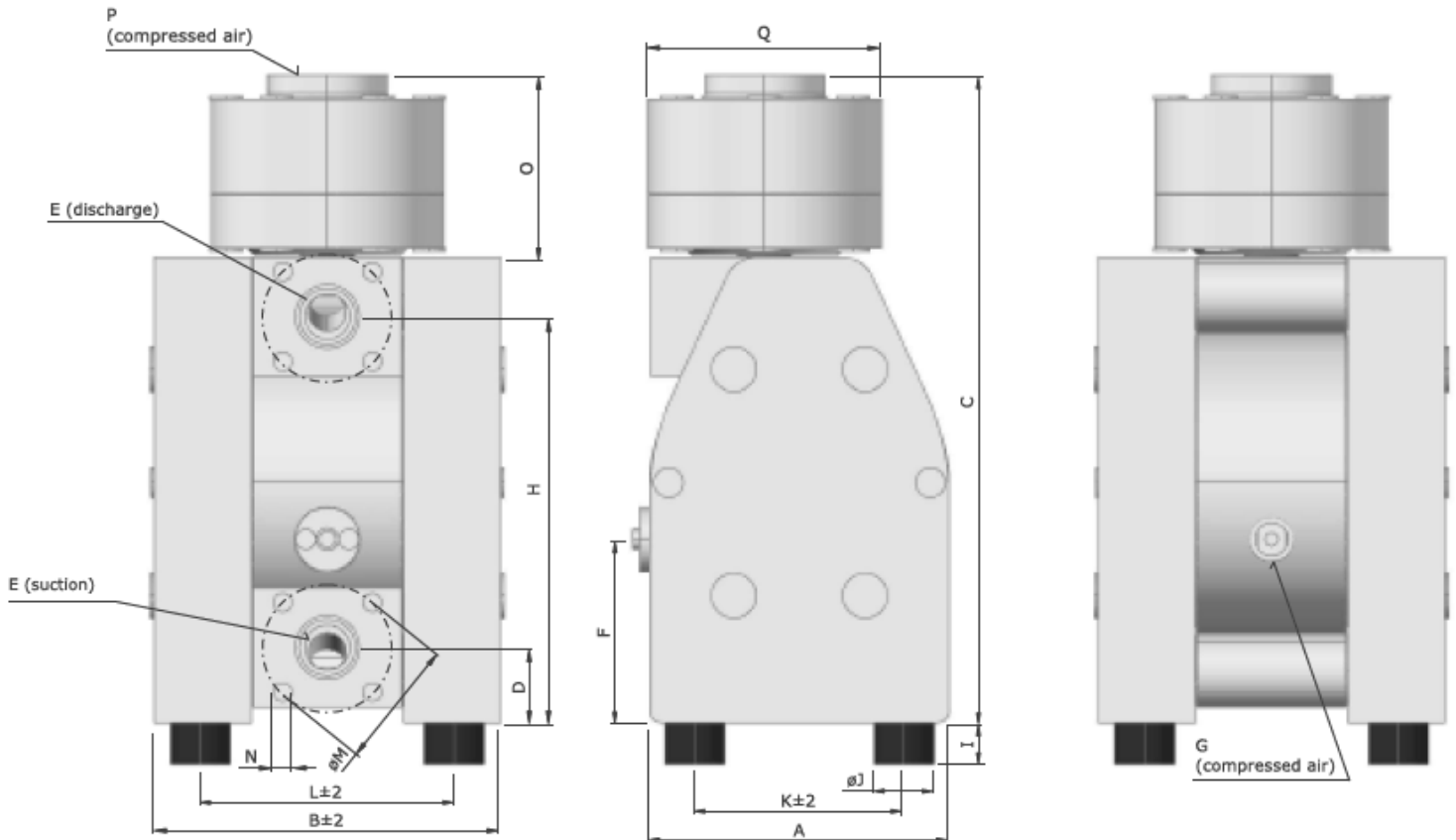

	A	B	C	D	E	F	G	H	I	ØJ	K	L	M	N	O	P	Q
DM 08/10	70	111	195	15	G 1/4"	58	R 1/8"	107	10	15	50	86	-	-	75	R 1/8"	76
DM 10/25	105	128	249	18	G 3/8"	84	R 1/8"	150	10	15	75	93	-	-	85	R 1/8"	110
DM 15/55	153	177	320	40	G 1/2"	87	R 1/4"	202	18	30	112	136	65	M12	85	R 1/8"	110
DM 25/125	200	232	432	50	G 1"	123	R 1/4"	272	28	40	140	170	85	M12	120	R 1/8"	156
DM 40/315	270	312	579	57	G 1 1/2"	109	R 1/2"	373	30	60	190	227	110	M16	153	R 1/4"	204
DM 50/565	350	385	726	52	G 2"	158	R 1/2"	478	30	60	270	282	125	M16	186	R 1/4"	273
DM 80/850	480	580	1061	100	G 3"	388	R 3/4"	690	40	75	395	495	160	M16	261	R 1/2"	360

15.3. Discharge port for pulsation damper assembly

Special discharge port allows you to mount the pulsation damper directly on the pump already bought (this doesn't apply the pump ordered together with pulsation damper – they're assembled in standard). It has to be replaced with the ordinary discharge port assembled in the pump.

Quantity	Pump size		DM 08	DM 10	DM 15	DM 25	DM 40	DM 50
	Description	Material	Part no.	Part no.	Part no.	Part no.	Part no.	Part no.
1	Outlet for Pulsation Damper	PE	2 08 27 20	2 10 27 20	2 15 27 20	2 25 27 20	2 40 27 20	2 50 27 20
		PTFE	2 08 27 23	2 10 27 23	2 15 27 23	2 25 27 23	2 40 27 23	2 50 27 23
		PE conductive	2 08 27 21	2 10 27 21	2 15 27 21	2 25 27 21	2 40 27 21	2 50 27 21
		PTFE conductive	2 08 27 24	2 10 27 24	2 15 27 24	2 25 27 24	2 40 27 24	2 50 27 24
1	Outlet with PN10 flange (F1, F2, F3 option) for pulsation damper	PE	-	-	2 15 26 20	2 25 26 20	2 40 26 20	2 50 26 20
		PTFE	-	-	2 15 26 23	2 25 26 23	2 40 26 23	2 50 26 23
		PE conductive	-	-	2 15 26 21	2 25 26 21	2 40 26 21	2 50 26 21
		PTFE conductive	-	-	2 15 26 24	2 25 26 24	2 40 26 24	2 50 26 24

16. Optional Equipment

**Additional information to the operating and installation instructions
ought to be studied before installing the pump**

For special requirements DELLMECO pneumatic diaphragm pumps of the Plastic Series can be furnished with several optional equipment. The pump code informs, which of these are included in the pump.

16.1. Barrier Chamber System (option code BC1, BC2, BC3)

To comply with high safety standards, the barrier system replaces the standard diaphragm [4] by a tandem arrangement of two diaphragms [4, 59] and a barrier chamber [53, 54] of conductive PE filled with a non-conductive liquid (de-ionized water) in between. To ensure the correct operation of the pump, the barrier chambers [53, 54] have to be filled completely. Therefore, they are monitored by liquid sensors [60]. After loosening the plug [57] the barrier liquid can be refilled. In case a diaphragm breaks, the conductivity of the barrier liquid rises which is registered by the conductivity sensors [56]. The minimum conductivity of 22 µS covers a wide range of media. Otherwise, a conductive barrier liquid can be filled into the chamber, so that the liquid emerging in case of a diaphragm rupture causes a decrease in conductivity to be registered. After using for some time the de-ionized water can be polluted with germs. In this case the water needs to be replaced.

The barrier system is available in three variations:

- BC 1 Barrier system with sensors, standard
- BC 2 Barrier system complete with sensors and controllers
- BC 3 Barrier system complete with sensors and controllers for explosion-proof zone

The four conductivity sensors [56] are pre-installed. After connection of the wire (wire not part of supply) only the PG-threads have to be screwed onto. Both liquid sensors [60] are installed completely.

The sensors can either be connected to an existing controller (code BC1) or to the controller included (code BC2 / BC3). The wiring diagram and technical data can be found on the controller itself. For further details, please refer to the data delivered by the manufacturers of the components. The controllers have to be installed in a suitable cabinet.

Spare part list, barrier chamber system

Code	Pos.	Quantity	Description	Pump size:					
				DM 10	DM 15	DM 25	DM 40	DM 50	
				Material	Part no.	Part no.	Part no.	Part no.	Part no.
BC 1	47	2	Suction / Discharge Ports	PE	2 10 32 20	2 15 32 20	2 25 32 20	2 40 32 20	2 50 32 20
				PTFE	2 10 32 23	2 15 32 23	2 25 32 23	2 40 32 23	2 50 32 23
				PE conductive	2 10 32 21	2 15 32 21	2 25 32 21	2 40 32 21	2 50 32 21
				PTFE conductive	2 10 32 24	2 15 32 24	2 25 32 24	2 40 32 24	2 50 32 24
	48	4 / 6* / 8**	Barrier chamber housing bolt	AISI 304	9 10 42 50	9 15 42 50*	9 25 42 50*	9 40 42 50**	9 50 42 50**
	49	1	Barrier chamber set screw shaft	AISI 304	1 10 41 50	1 15 41 50	1 25 41 50	1 40 41 50	1 50 41 50
	50	2	Spacer	PET	1 10 63 30	1 15 63 30	1 25 63 30	-	-
	51	2	Spacer bolt	AISI 304	1 10 43 50	-	-	-	-
	52	1	Left barrier chamber	PE conductive	2 10 02 21	2 15 02 21	2 25 02 21	2 40 02 21	2 50 02 21
	53	1	Right barrier chamber	PE conductive	2 10 102 21	2 15 102 21	2 25 102 21	2 40 102 21	2 50 102 21
	54	2	Sensor sleeve	PE	2 10 62 20	2 15 62 20	2 25 62 20	2 40 62 20	2 50 62 20
	55	2	Sensor sleeve o-ring	FKM	1 08 82 09	1 08 82 09	1 08 82 09	1 08 82 09	1 08 82 09
	56	4	Conductivity sensor	diverse	9 15 15 00	9 15 15 00	9 15 15 00	9 15 15 00	9 15 15 00
	57	2	Plug	PA	1 15 48 40	1 15 48 40	1 15 48 40	1 15 48 40	1 15 48 40
	58	2	Plug o-ring	FKM	1 15 74 09	1 15 74 09	1 15 74 09	1 15 74 09	1 15 74 09
	59	2	Inner diaphragm	EPDM	1 10 51 08	1 15 51 08	1 25 51 08	1 40 51 08	1 50 51 08
	60	2	NAMUR liquid sensor	diverse	9 15 12 00	9 15 12 00	9 15 12 00	9 15 12 00	9 15 12 00
61	2	Liquid sensor o-ring	FKM	1 15 75 09	1 15 75 09	1 15 75 09	1 15 75 09	1 15 75 09	
BC 2	as BC1, but additionally contains:								
	-	1	Controller	diverse	9 15 14 00	9 15 14 00	9 15 14 00	9 15 14 00	9 15 14 00
	-	1	Conductivity measuring trans.	diverse	9 15 13 00	9 15 13 00	9 15 13 00	9 15 13 00	9 15 13 00
BC 3	as BC2, but for EExia II C:								
	-	1	Controller	diverse	9 15 14 00	9 15 14 00	9 15 14 00	9 15 14 00	9 15 14 00
	-	1	Conductivity measuring trans.	diverse	9 15 08 00	9 15 08 00	9 15 08 00	9 15 08 00	9 15 08 00

Exploded view, barrier chamber system for DM 10

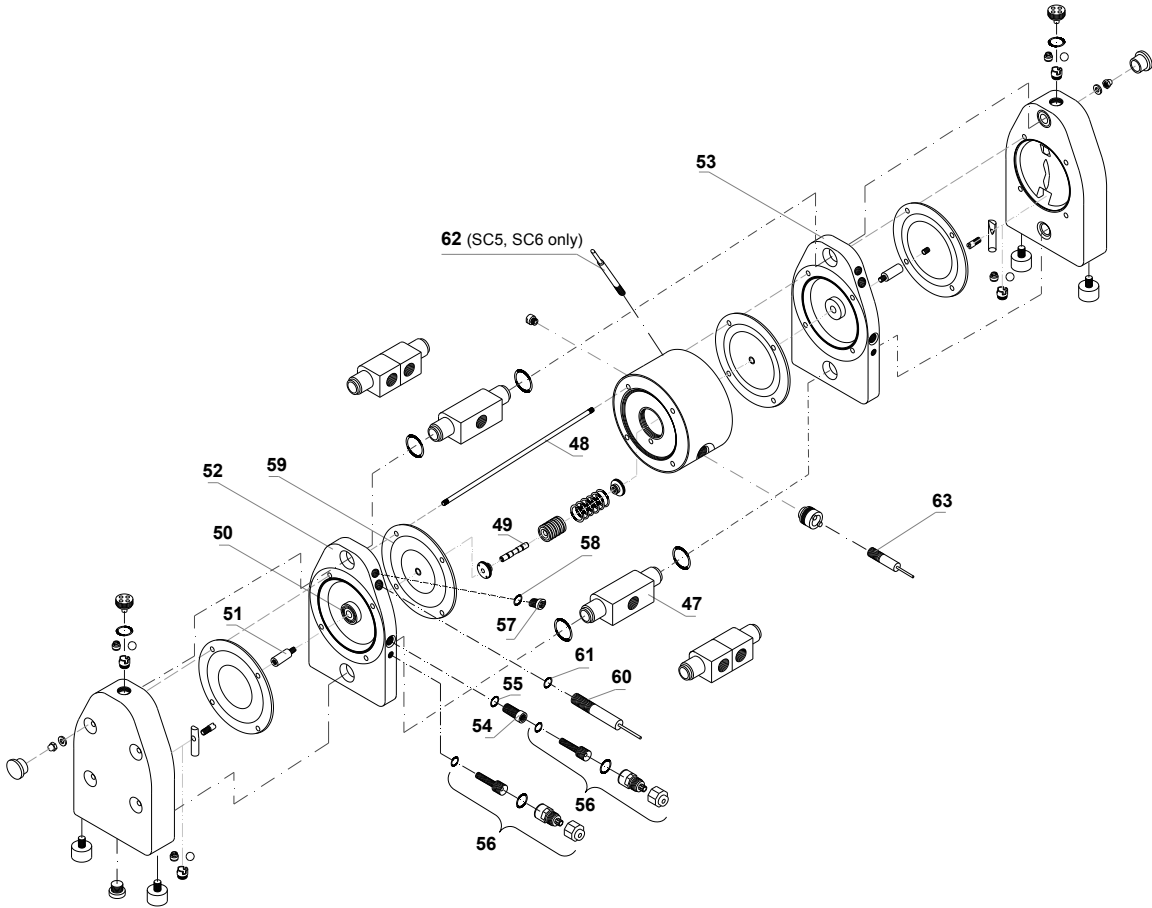

Exploded view, barrier chamber system for DM 15, 25, 40, 50

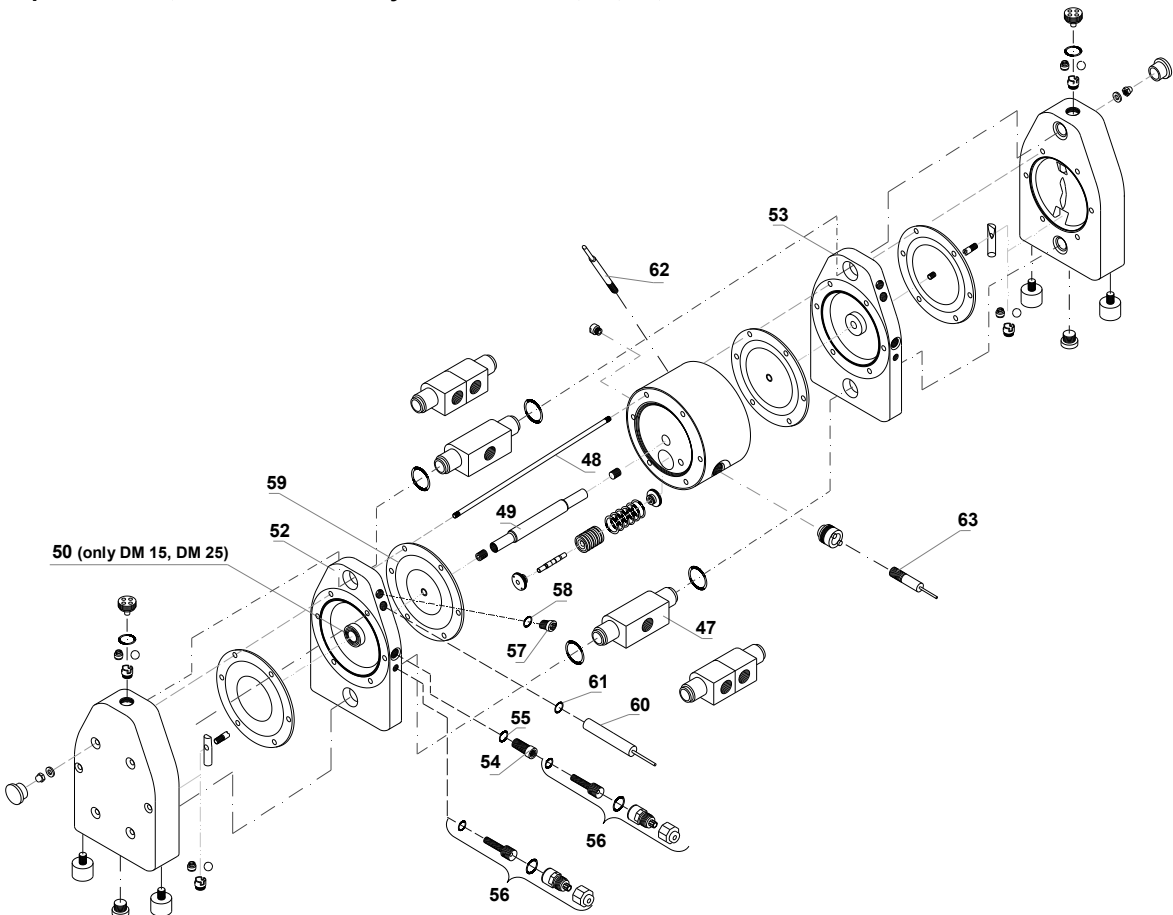

Appearance and dimensions (pump with Barrier Chamber System)

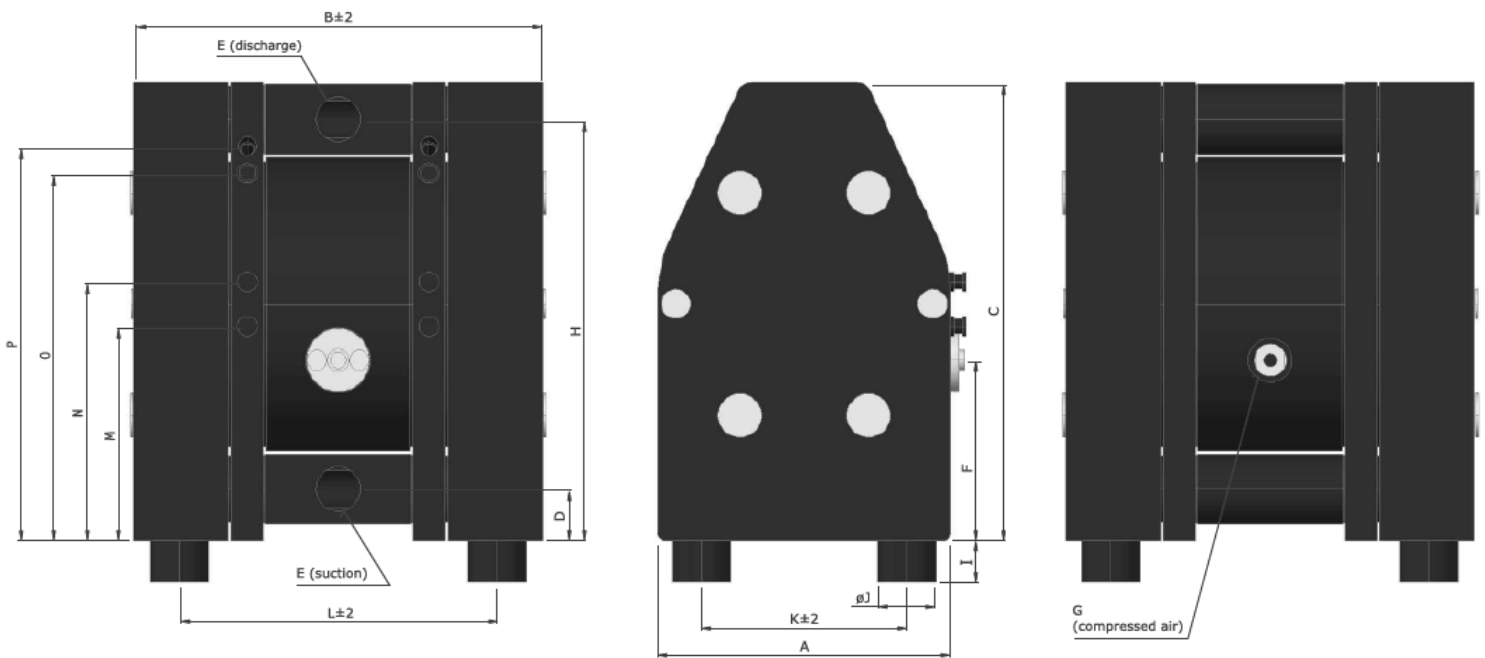

	A	B	C	D	E	F	G	H	I	ØJ	K	L	M	N	O	P
DM 10/25	105	173	164	18	G 3/8"	84	R 1/8"	150	10	15	75	138	61	84	128	146
DM 15/55	153	223	235	25	G 1/2"	87	R 1/4"	217	18	30	112	182	86	111	191	209
DM 25/125	200	282	312	35	G 1"	123	R 1/4"	287	28	40	140	220	146	176	250	270
DM 40/315	270	360	426	42	G 1 1/2"	109	R 1/2"	388	30	60	190	276	204	229	349	369
DM 50/565	350	433	540	45	G 2"	158	R 1/2"	485	30	60	270	335	253	278	443	463

16.2. Stroke Counting (option code SC1, SC2, SC3, SC5, SC6)

a) Code SC1, SC2, SC3

A sensor is installed in the central pump housing to count the strokes. The diaphragm movement is scanned without contact by this sensor: a safe form of monitoring totally independent of external influences and the pump's mode of operation. The issued sensor pulses can be output to existing detectors or to a stroke counter, which can also be supplied on request. When the preset value is reached, the stroke counter outputs a signal which can then be processed further, for instance in order to shut down the pump via a solenoid valve.

The stroke counting system is available in three variations:

- SC 1 Stroke sensor (NAMUR), also for explosion-proof zone
- SC 2 Stroke counting system complete with sensor and stroke counter
- SC 3 Stroke counting system complete with sensor, stroke counter and controller for explosion-proof zone

In case only the sensor is included (code SC1), it has to be connected to an existing controller with NAMUR inlet. For applications an explosion-proof device is required for (code SC3) the intrinsically safe controller has to be installed between the sensor and the counter. The wiring diagram and technical data can be found on the electric units themselves. For further details, please refer to the data delivered by the manufacturers of the components. The controllers have to be installed in a suitable cabinet.

b) Code SC5, SC6

Differently from the optional equipment codes SC1-SC3, the strokes of the pump are registered pneumatically on the codes SC5 and SC6. The pressure transmitter registers the changes in pressure within the air chamber behind one of the diaphragms and it converts the pneumatic impulse into an electrical signal.

The pneumatic stroke counting system is available in two types:

- **SC 5** consist of:
 - pressure transmitter 1-10 bar
 - socket with cable 2,5 m
 - adaptor elbow NPT ¼ (or adaptor straight M5 for DM 08, DM 10 pumps only)
 - hose DN 4/6; 2,5m
- **SC 6** consist of:
 - SC 5 plus stroke counter

For assembly, screw the adaptor straight into the pressure transmitter (connection P1) and adaptor elbow (or adaptor straight for DM 08 and DM 10 pumps) into the additional air connection of the pump (it is possible that the adaptors are already installed). The position of the air inlet varies depending in the pump type and the pump size (see comments below). Link up both adaptors with the hose. Connect the socket to the electrical connection plug of the pressure transmitter and the cable to existing registering devices (Code SC5) resp. to the enclosed stroke counter (Code SC6). Technical data, connection schemes and further details can be found in the technical documentation delivered by the manufacturers of the pressure transmitter and the stroke counter.



! The pneumatic stroke counting system requires a minimum air pressure of 1.5 bar for optimal function.

The air inlet for the pneumatic stroke counting system must not be confused with the actual air inlet of the pump. Therefore, you will find some advises adapted to the pump type and the pump size.

Spare part list, stroke counting

				Pump size:	DM 08	DM 10	DM 15	DM 25	DM 40	DM 50	DM 80
Code	Pos.	Quantity	Description	Material	Part no.	Part no.	Part no.	Part no.	Part no.	Part no.	Part no.
SC 1	2	1	Center housing for sensor	PE	-	-	1 15 09 20	1 25 09 20	1 40 09 20	1 50 09 20	1 80 09 20
				PE conductive	-	-	1 15 09 21	1 25 09 21	1 40 09 21	1 50 09 21	1 80 09 21
	62	1	Stroke sensor	diverse	-	-	9 15 16 00	9 15 16 00	9 15 16 00	9 15 16 00	9 15 16 00
SC 2	as SC 1, but additionally contains:										
	-	1	Clamp amplifier	diverse	-	-	9 15 18 00	9 15 18 00	9 15 18 00	9 15 18 00	9 15 18 00
	-	1	Stroke counter	diverse	-	-	9 15 17 00	9 15 17 00	9 15 17 00	9 15 17 00	9 15 17 00
SC 3	as SC 1, but additionally contains:										
	-	1	Level controller	diverse	-	-	9 15 14 00	9 15 14 00	9 15 14 00	9 15 14 00	9 15 14 00
	-	1	Stroke counter	diverse	-	-	9 15 17 00	9 15 17 00	9 15 17 00	9 15 17 00	9 15 17 00
SC 5	2	1	Center housing with additional air connection R 1/4	PE	1 08 109 20	1 10 109 20	1 15 109 20	1 25 109 20	1 40 109 20	1 50 109 20	-
				PE conductive	1 08 109 21	1 10 109 21	1 15 109 21	1 25 109 21	1 40 109 21	1 50 109 21	-
	-	1	Adaptor elbow	PP	-	-	1 08 092 28	1 08 092 28	1 08 092 28	1 08 092 28	-
	-	1	Adaptor straight	PP	1 08 192 28	1 08 192 28	-	-	-	-	-
	-	1	Hose 2,5 m	PE	1 08 292 20	1 08 292 20	1 08 292 20	1 08 292 20	1 08 292 20	1 08 292 20	-
	-	1	Pressure transmitter	diverse	9 08 28 00	9 08 28 00	9 08 28 00	9 08 28 00	9 08 28 00	9 08 28 00	-
	-	1	Socket with cable 2,5m	diverse	1 08 392 00	1 08 392 00	1 08 392 00	1 08 392 00	1 08 392 00	1 08 392 00	-
SC 6	as SC5, but additionally contains:										
	-	1	Stroke counter	diverse	9 15 17 00	9 15 17 00	9 15 17 00	9 15 17 00	9 15 17 00	9 15 17 00	-

16.3. Diaphragm Monitoring (option code DM1, DM2)

Although DELLMECO diaphragms with integrated metal core are designed for an optimum service life, the diaphragm remains a wear part. If it breaks, liquid can leak into the center housing and possibly emerge through the muffler. This can be prevented simply and effectively with the DELLMECO diaphragm monitoring.

A capacitive diaphragm sensor is mounted in the muffler [17] of the pump, which registers any liquid approaching the sensor, no matter whether the liquid is conductive or not. Hence, a fast reaction to a damage of a diaphragm becomes possible. In case of humid surrounding air a false alert may occur despite operating the pump with dried compressed air.

The diaphragm monitoring system is available in two variations:

- DM1 Diaphragm sensor (NAMUR), also for explosion-proof area
- DM2 Diaphragm monitoring system complete with sensor and controller

The diaphragm sensor can either be connected to an existing controller with NAMUR inlet (code DM1) or to the controller included (code DM2). The wiring diagram and technical data can be found on the controller itself. For further details, please refer to the data delivered by the manufacturers of the components. The controllers have to be installed in a suitable cabinet.

Spare part list, diaphragm monitoring

					Pump size:				
					DM 10	DM 15	DM 25	DM 40	DM 50
Code	Position	Quantity	Description	Material	Part no.	Part no.	Part no.	Part no.	Part no.
DM 1	63	1	Diaphragm sensor, NAMUR	diverse	9 15 19 00	9 15 19 00	9 15 19 00	9 15 19 00	9 15 19 00
DM 2	63	1	Diaphragm sensor, NAMUR	diverse	9 15 19 00	9 15 19 00	9 15 19 00	9 15 19 00	9 15 19 00
	-	1	Controller	diverse	9 15 14 00	9 15 14 00	9 15 14 00	9 15 14 00	9 15 14 00

16.4. Flange Connections (option code F1, F2, F3, F4, F7, F8, F9)

This version offers the possibility to use flange connectors according to: DIN/PN10 (options: **F1, F2, F3**), JIS 5K (option **F4**), PN10 DIN 2576 (option **F7**), ANSI 150 RF-SO (option **F8**), or PN16 DIN 2277/2278 (option **F9**). For options: F1, F2, F3 thread bushings, made of stainless steel to fix the flanges, are included in the inlet/outlet discharge. The O-rings attached have to be inserted into the grooves of the manifolds to improve sealing before connecting the pump.

Spare part list, flange connection

					Pump size:			
					DM 15	DM 25	DM 40	DM 50
Code	Pos.	Quantity	Description	Material	Part no.	Part no.	Part no.	Part no.
F1	-	2	DIN/PN10 flange connection	PE	2 15 25 20	2 25 25 20	2 40 25 20	2 50 25 20
				PTFE	2 15 25 23	2 25 25 23	2 40 25 23	2 50 25 23
				PE conductive	2 15 25 21	2 25 25 21	2 40 25 21	2 50 25 21
				PTFE conductive	2 15 25 24	2 25 25 24	2 40 25 24	2 50 25 24
	-	8	Flange thread bushing	AISI 304	9 15 47 50	9 15 47 50	9 40 47 50	9 40 47 50
-	2	Flange o-ring	EPDM	2 15 78 08	2 25 78 08	2 40 78 08	2 50 78 08	
F2	-	2	as F1, but: Flange o-ring	NBR	2 15 78 10	2 25 78 10	2 40 78 10	2 50 78 10
F3	-	2	as F1, but: Flange o-ring	FEP/FKM	2 15 78 04	2 25 78 04	2 40 78 04	2 50 78 04
F4	-	2	Flange pipe	PE	2 15 125 20	2 25 125 20	2 40 125 20	2 50 125 20
				PTFE	2 15 125 23	2 25 125 23	2 40 125 23	2 50 125 23
				PE conductive	2 15 125 21	2 25 125 21	2 40 125 21	2 50 125 21
				PTFE conductive	2 15 125 24	2 25 125 24	2 40 125 24	2 50 125 24
	-	2	JIS 5K flange collar	PE	2 15 525 20	2 25 525 20	2 40 525 20	2 50 525 20
-	2	PE conductive	2 15 525 21	2 25 525 21	2 40 525 21	2 50 525 21		
F7	-	2	as F4, but: PN10/DIN 2576 flange collar	PE	2 15 225 20	2 25 225 20	2 40 225 20	2 50 225 20
-	2	PE conductive	2 15 225 21	2 25 225 21	2 40 225 21	2 50 225 21		
F8	-	2	as F7, but: ANSI 150 RF-SO flange collar	PE	2 15 325 20	2 25 325 20	2 40 325 20	2 50 325 20
-	2	PE conductive	2 15 325 21	2 25 325 21	2 40 325 21	2 50 325 21		
F9	-	2	as F7, but: PN16 DIN 2277/2278 flange collar	PE	2 15 425 20	2 25 425 20	2 40 425 20	2 50 425 20
-	2	PE conductive	2 15 425 21	2 25 425 21	2 40 425 21	2 50 425 21		

16.5. Sleeve with Split Connections (option code S)

The pump size DM 10, 15, .., 50 P.. of the Plastic Series can be converted from a double-acting air-driven diaphragm pump into two separated single-acting ones. The standard sleeve with one suction and one discharge connection is exchanged for a sleeve with split connections, so with separate suction and discharge connections for both pump chambers. By separation in two pump halves with the same drive there are two liquid streams in 1:1 ratio.

The illustrations on pages: 6, 8 and 10 show configuration of the split connections. The nominal port size is the same as in standard sleeve (e.g. for DM 10 is G 3/8 ").

Spare part list, split connections

				Pump size:					
				DM 10	DM 15	DM 25	DM 40	DM 50	
Code	Position	Quantity	Description	Material	Part no.	Part no.	Part no.	Part no.	
S	64	2	Sleeve with split connections	PE	2 10 31 20	2 15 31 20	2 25 31 20	2 40 31 20	2 50 31 20
				PE conductive	2 10 31 21	2 15 31 21	2 25 31 21	2 40 31 21	2 50 31 21
				PTFE	2 10 31 23	2 15 31 23	2 25 31 23	2 40 31 23	2 50 31 23
				PTFE conductive	2 10 31 24	2 15 31 24	2 25 31 24	2 40 31 24	2 50 31 24

16.6 Back Flushing System (option code BF1, BF2, BF4, BF5)

A pump equipped with the back flushing system (ball lift system) can be emptied along with an inclining discharge line while being installed within the plant. It consists of a bypass-system in the side housings which can be activated by manual valves (code BF1, BF2) or pneumatically (code BF4, BF5).

Open the manual valves (BF1, BF2) by approx. 10mm by turning to the left (Attention: As there is no blocking of the valves, it has to be ensured not to take them out completely). The pump should be kept in operation meanwhile. Slow down the pump slowly and finally stop it.

The drawing below illustrates the flushing system (code BF4, BF5, minimum air pressure 3 bar). By attaching a 4-2-way valve (not included in the delivery), the back flushing system can be activated automatically when cutting off the pump.

Side housing O-rings are made of EPDM (code BF1, BF4) or FEP/FKM (code BF2, BF5).

Appearance of back flushing system

Manual Back Flushing System

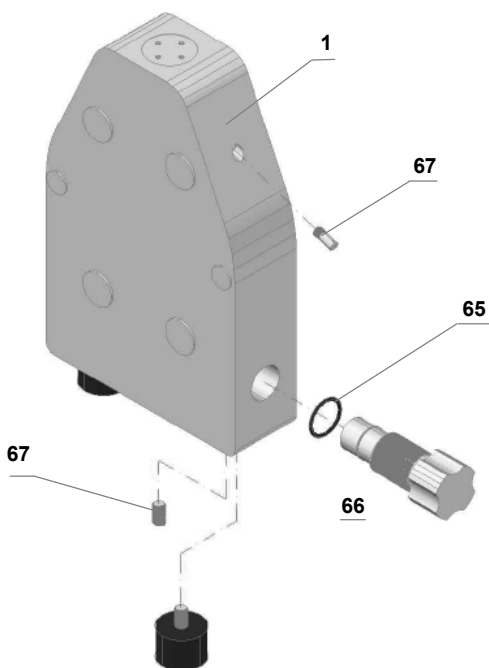

Pneumatic Back Flushing System

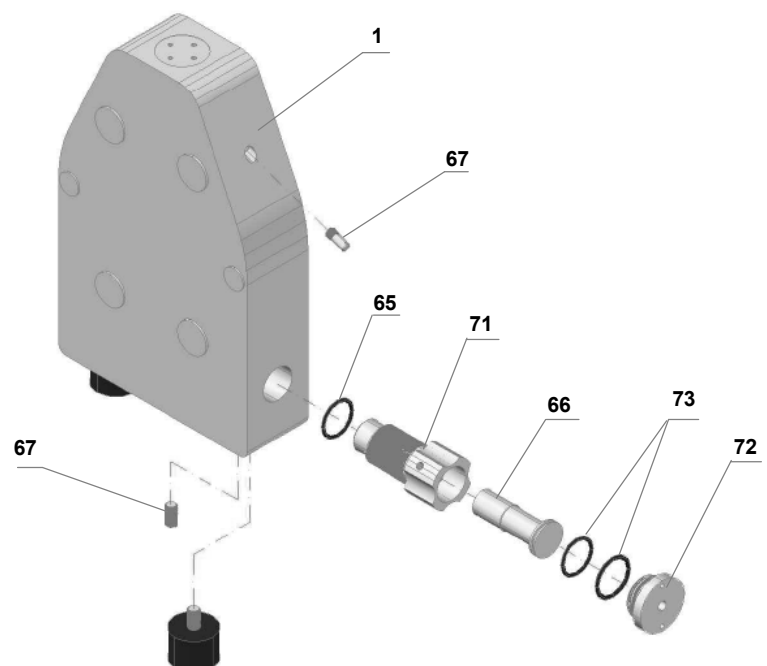

Spare part list, back flushing system

				Pump size:	DM 15	DM 25	DM 40	DM 50
Code:	Item	Pcs.	Description	Material	Part no.	Part no.	Part no.	Part no.
BF1	1	1	Pump housing left for BF system	PE	2 15 001 20	2 25 001 20	2 40 001 20	2 50 001 20
				PE-conductive	2 15 001 21	2 25 001 21	2 40 001 21	2 50 001 21
				PTFE	2 15 001 23	2 25 001 23	2 40 001 23	2 50 001 23
				PTFE conductive	2 15 001 24	2 25 001 24	2 40 001 24	2 50 001 24
		1	Pump housing right for BF system	PE	2 15 301 20	2 25 301 20	2 40 301 20	2 50 301 20
				PE-conductive	2 15 301 21	2 25 301 21	2 40 301 21	2 50 301 21
				PTFE	2 15 301 23	2 25 301 23	2 40 301 23	2 50 301 23
				PTFE conductive	2 15 301 24	2 25 301 24	2 40 301 24	2 50 301 24
	65	2	O-ring for pump housing	EPDM	2 15 70 08	2 15 70 08	2 40 072 08	2 50 072 08
				FEP/FKM	2 15 70 04	2 15 70 04	2 40 072 04	2 50 072 04
	66	2	Drain plug	PE conductive	2 15 066 21	2 25 066 21	2 40 066 21	2 50 066 21
				PTFE conductive	2 15 066 24	2 25 066 24	2 40 066 24	2 50 066 24
	67	4	Plug	PE	2 15 067 20	2 25 067 20	2 40 067 20	2 50 067 20
				PE conductive	2 15 067 21	2 25 067 21	2 40 067 21	2 50 067 21
PTFE				2 15 067 23	2 25 067 23	2 40 067 23	2 50 067 23	
PTFE conductive				2 15 067 24	2 25 067 24	2 40 067 24	2 50 067 24	
BF2	As BF1 but:							
	65	2	O-ring for pump housing	FEP/FKM	2 15 70 04	1 40 86 04	2 40 072 04	2 50 072 04
BF4	As BF1 but:							
	65	2	O-ring for pump housing	FEP/FKM	2 15 70 04	2 15 70 04	2 40 072 04	2 50 072 04
	66	2	Piston	PTFE	2 15 068 23	2 25 068 23	2 40 068 23	2 50 068 23
	71	2	Piston housing	PE conductive	2 15 266 21	2 25 266 21	2 40 266 21	2 50 266 21
	72	2	Piston cover	PE conductive	2 15 168 21	2 25 168 21	2 40 168 21	2 50 168 21
	73	4	O-ring for piston and cover	EPDM	2 15 78 08	2 15 78 08	2 40 272 08	2 50 272 08
BF5	As BF4 but:							
	73	4	O-ring for piston and cover	NBR	2 15 272 10	2 25 272 10	2 40 272 10	2 50 272 10

16.7 High Pressure System (option code HP)

DELLMECO diaphragm pumps can be fitted with High Pressure option. It is a very compact unit that can be mounted directly to the filter press. It has been designed for charging filter presses with chemical wastes and special sludge. An external pressure booster doubles or quadruples the delivery pressure.

Filter presses with DELLMECO HP pump

Automatic adaptation

When slurry is transferred to a chamber filter press, first the chambers get filled while the pressure tends to zero. Under the increasing filling-level the solids assemble at the filter cloths. This requires a pressure that continuously rises with the increasing content of solids. Under a constant flow quantity the pressure would rise extremely fast.

The drive of the HP pump by compressed air causes a diminution of the flow quantity according to the increasing counter-pressure in the filter press. This produces a soft filtration curve, automatically self-regulating according to the filling level of the filter press. This is independent from the properties of the slurry. No pressure tank nor pressure transmitter nor speed control are required. The complete HP pump works without electric energy.

End of filtration process

When the filter press is filled with the solids so far that no more slurry can be taken up, the pressing period is terminated. The air operation of the DELLMECO pumps then reduces the flow rate to zero while the outlet pressure holds the required level compressing the filter cake. Excellent results in drying are obtained. At the end of the pressing period the pump simply stops.

Pressure adjustment

The required pressure in the filter press is comfortably adjusted by the height of the air pressure supplying the charging station. For a required pressure of 12 bar the HP pump has to be supplied with 6 bar when the pump with a pressure transmission of 1:2 is applied. In the case that higher pressures are necessary or there is only a lower air pressure available, the HP pump with 1:4 transmission is applied.

Low air consumption

The charging stations needs the maximum air quantity only during the filling period. The more the press is filled, the more slowly the pump works. So the air consumption slowly reaches zero during progressing filtration.

Appearance and dimensions of high pressure system (pump with HP option)

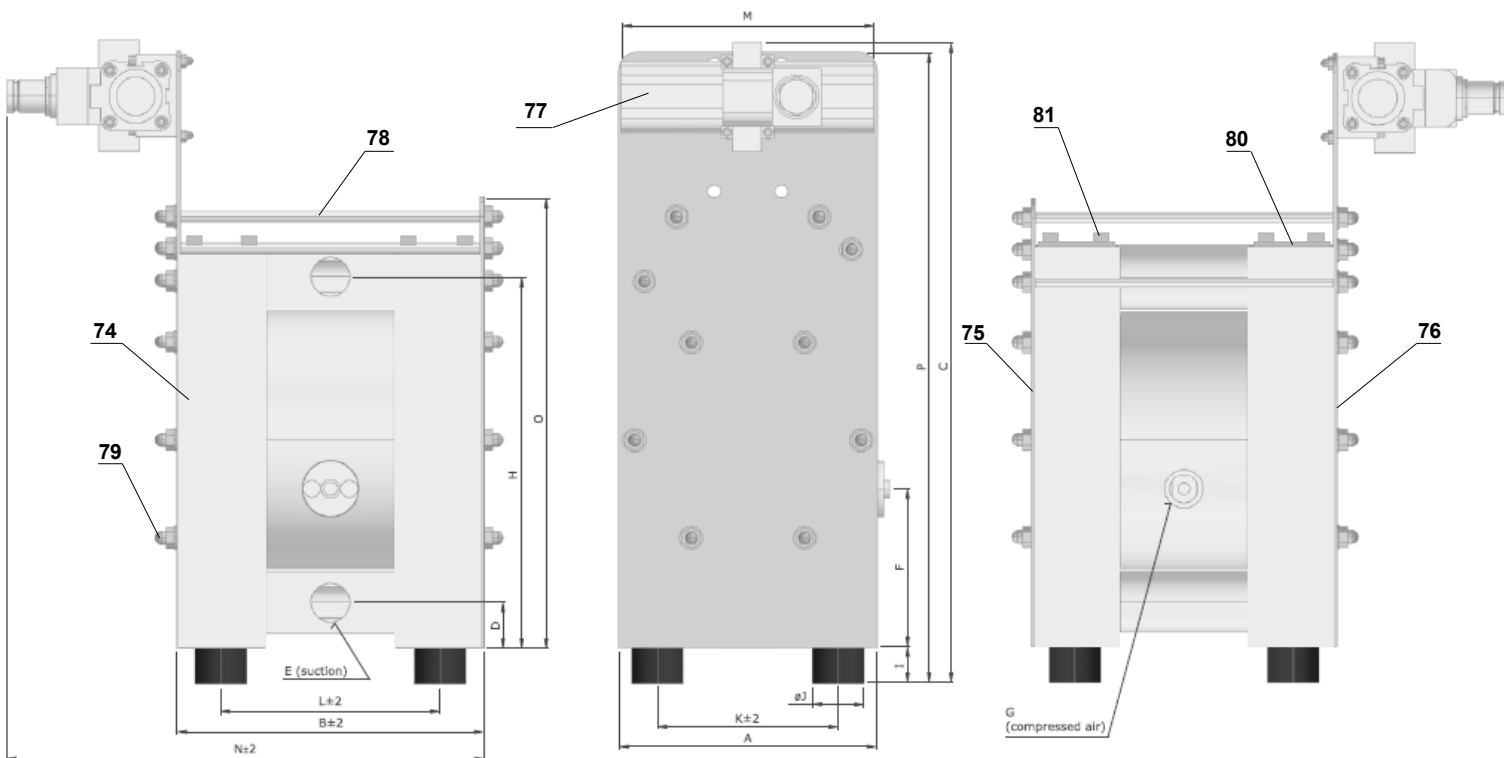

	A	B	C	D	E	F	G	H	I	ØJ	K	L	M	N	O	P
DM 15/55	153	182	372	25	G 1/2"	87	R 1/4"	217	18	30	112	136	195	321	253	333
DM 25/125	200	238	-	35	G 1"	123	R 1/4"	287	28	40	140	170	291	422	349	462
DM 40/315	270	318	-	42	G 1 1/2"	109	R 1/2"	388	30	60	190	227	291	529	500	600
DM 50/565	350	393	-	45	G 2"	158	R 1/2"	485	30	60	270	282	404	614	560	690

Spare part list, high pressure system

Code	Item	Pcs.	Description	Material	Part no.	Part no.	Part no.	Part no.
HP	74	2	Pump housing for HP option	PE	2 15 601 20	2 25 601 20	2 40 601 20	2 50 601 20
				PE conductive	2 15 601 21	2 25 601 21	2 40 601 21	2 50 601 21
				PTFE	2 15 601 23	2 25 601 23	2 40 601 23	2 50 601 23
				PTFE conductive	2 15 601 24	2 25 601 24	2 40 601 24	2 50 601 24
	75	1	Distance plate short	AISI 304	2 15 164 50	2 25 164 50	2 40 164 50	2 50 164 50
	76	1	Distance plate long	AISI 304	2 15 264 50	2 25 264 50	2 40 264 50	2 50 264 50
	77	1	Air pressure booster	Diverse	9 15 64 00	9 15 64 00	9 40 64 00	9 50 64 00
	78	10 / 12*	Housing bolt	AISI 304	2 15 142 50	2 25 142 50	2 40 142 50*	2 50 142 50*
	79	20 / 24*	Distance plate nut	AISI 304	1 15 45 50	1 25 45 50	1 40 45 50*	1 50 45 50*
80	2	Plate for upper plug	AISI 304	1 15 464 50	1 25 464 50	1 40 464 50	1 50 464 50	
81	8	Upper plug plate screw	AISI 304	1 15 564 50	1 25 564 50	1 40 564 50	1 50 564 50	

Performance curves

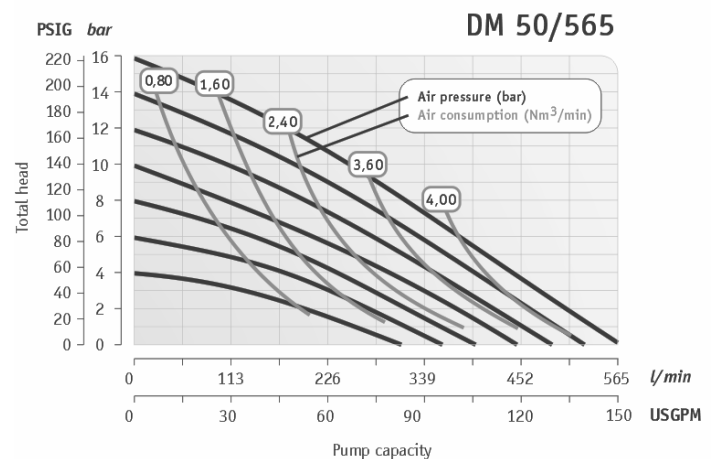
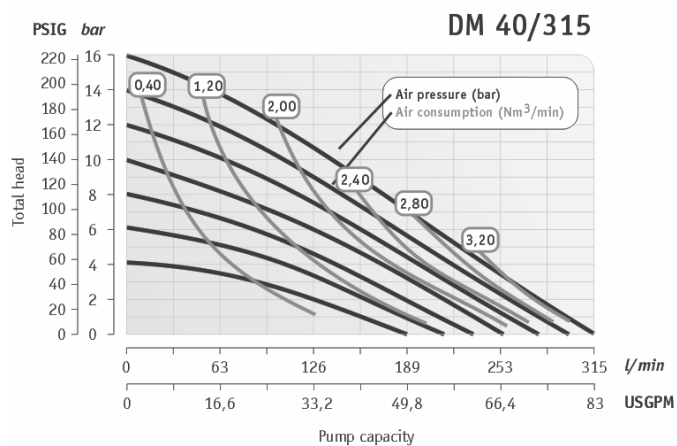
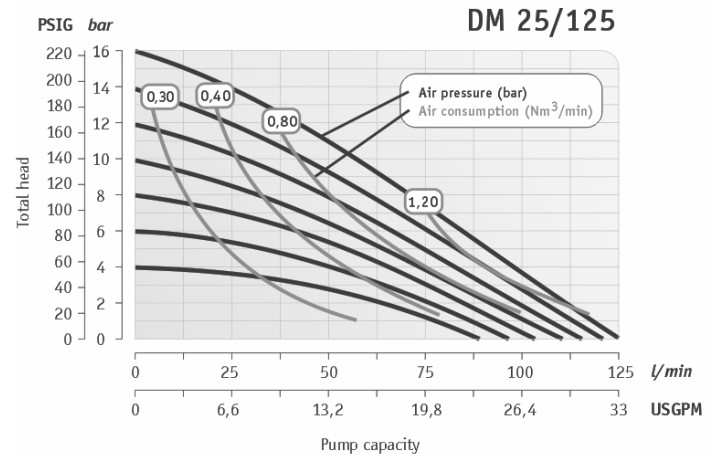
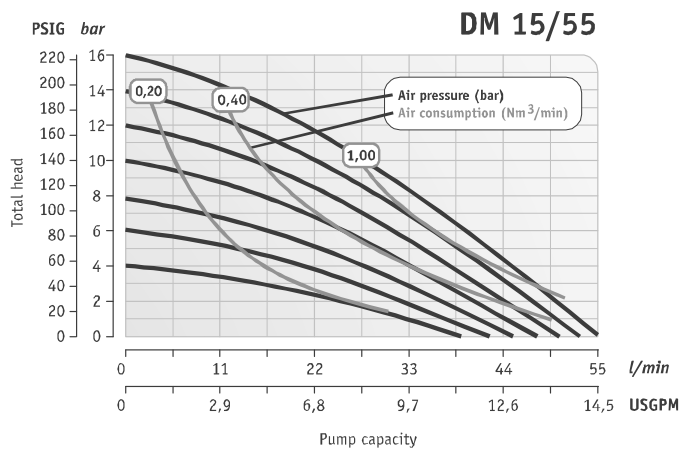

17. Limited warranty

This product is shipped to customers only after meeting strict inspection standards. If an abnormality occurs during normal operation in accordance with the operating instructions and other operating cautions within the warranty period (24 months after date of purchase) that can be attributed to a manufacturing defect, the defective parts of this product will be serviced or the product will be replaced free of charge. However, this warranty will NOT cover compensation for incidental damage or any malfunction listed below.

1. Warranty period

This warranty is valid for 24 months after the date of purchase.

2. Warranty

If, during the warranty period, any of the material of the genuine parts of this product or the workmanship of this product is found defective, and is so verified by our company, the servicing cost will be fully covered by our company.

3. Exclusion

Even during the warranty period, this warranty DOES NOT cover the following:

- 1) Malfunction caused by the use of parts other than manufacturer-specified genuine parts.
- 2) Malfunction caused by misuse or operating errors, or lack of storage or maintenance care.
- 3) Malfunction caused by the use of a fluid that may cause corrosion, inflation or dissolution of the component parts of the product.
- 4) Irregularity caused by a repair made by other than our firm, our regional office, dealer or authorized service personnel.
- 5) Malfunction caused by a modification of the product by other than authorized service personnel.
- 6) Wear and tear of parts that must be regularly replaced in the course of normal operation, such as diaphragms, valve seats, balls, air motor sleeve valves and o-rings.
- 7) Malfunction and/or damage due to transportation, moving or droppage of the product after purchase.
- 8) Malfunction and/or damage due to fire, earthquake, flood or other force majeure.
- 9) Malfunction caused by the use of compressed air that contains impurities, air with oil or excessive moisture, or use of gases or fluids other than the specified compressed air.
- 10) Malfunction caused by the use of a fluid that causes excessive abrasion.

Furthermore, this warranty does not cover the rubber parts, or other parts that are subject to wear in normal operation, used in this product and its accessories.

4. Parts

Parts for this product will be kept available for 5 years after discontinuation of production. Once 5 years have elapsed after close of production, availability of parts for this product cannot be guaranteed.

Notes:

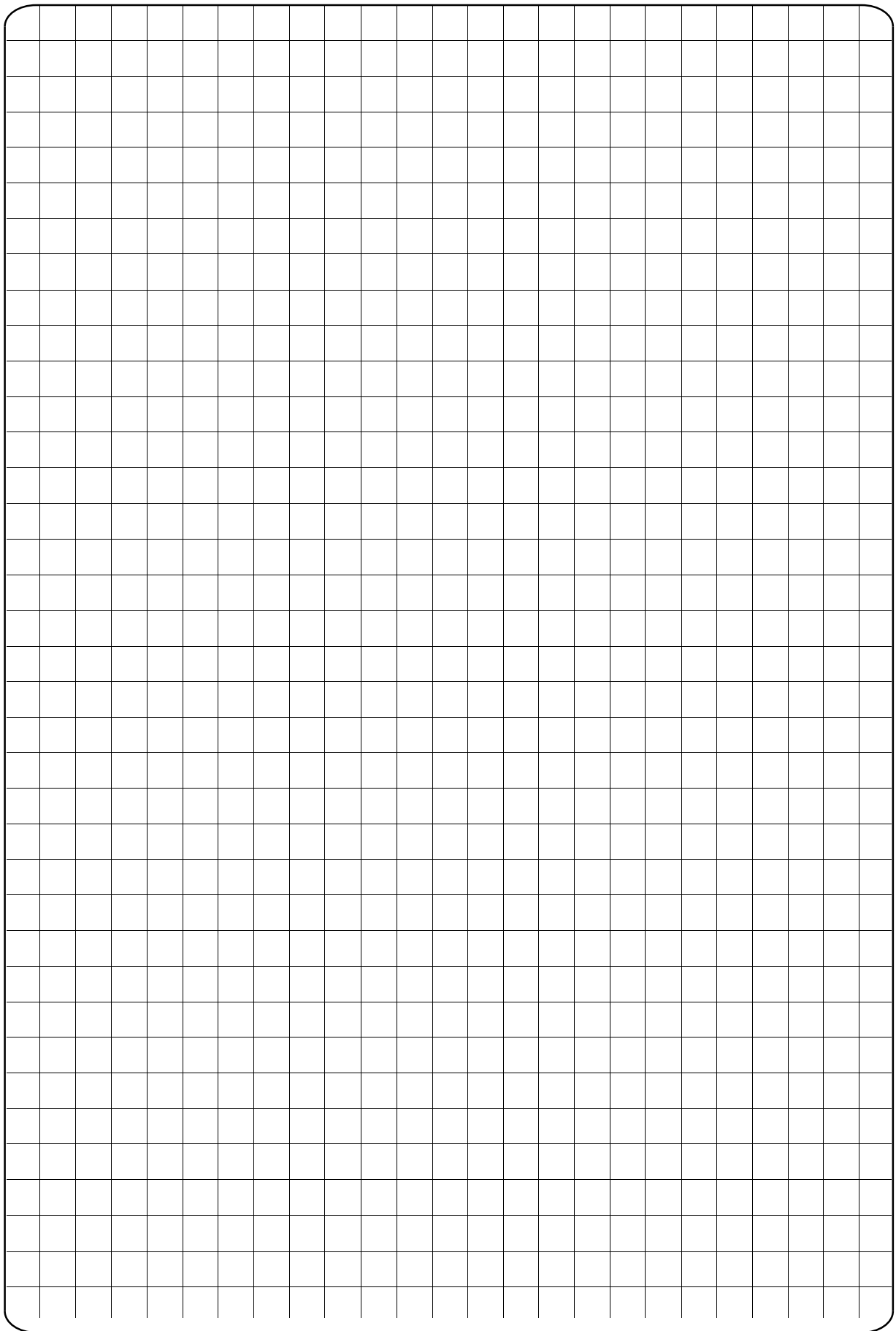

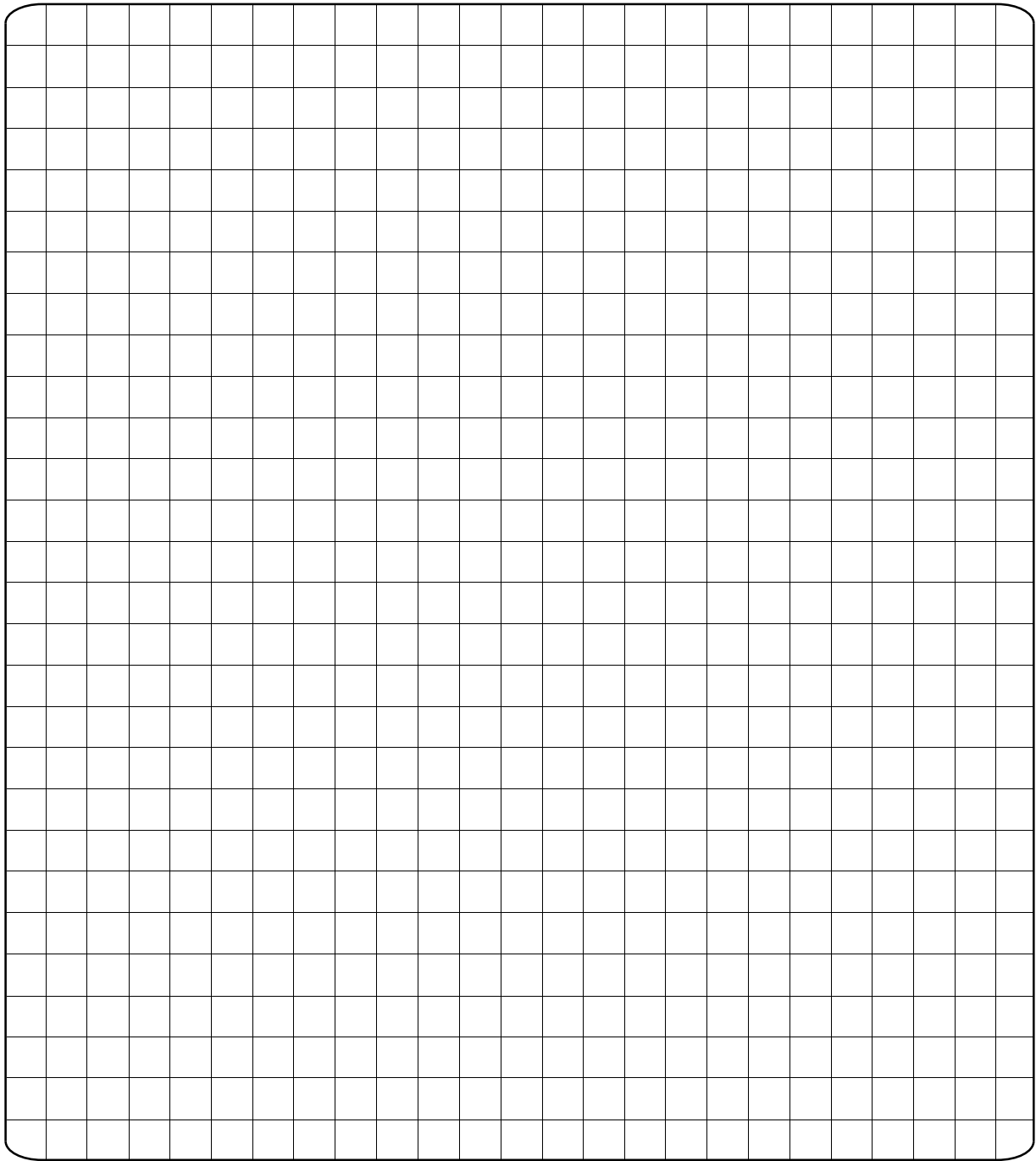

DELLMECO LTD

Unit 1, Willow Row
Longton
Stoke on Trent
Staffordshire
ST3 2PU
United Kingdom
tel. +44 1782 793 029
fax: +44 1782 501 721



sales@dellmeco.com
www.dellmeco.com