

## TM3 Pumps<sup>©</sup>



- Capacity 10 – 530 l/min
- 2" connections
- Suitable for viscosity liquids >3000 cP
- Max. sizes solid parts in liquid 6 m
- Viscosity up to 30 000 cP
- Pump body: Alu. (Komaxit coated)
- Low noise (75 dBa)
- Low air-consumption !
- Dry running capability
- Low maintenance and parts costs
- Bolted (SST) leakage free design
- No Air leakage at liquid stop



**Each pump tested  
Test report included**

## APPLICATIONS

CHEMICALS • SOLVENTS • PLATING • ACIDS • OILS • INKS • GLUES • ALKALIES • ENAMEL  
POLYESTER PAINT • WASTE WATER • COOLING LIQUIDS • FOAMS • HYDRAULIC OILS

### Flowchart 2" Series

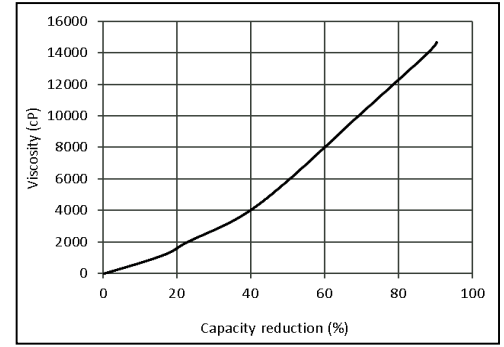
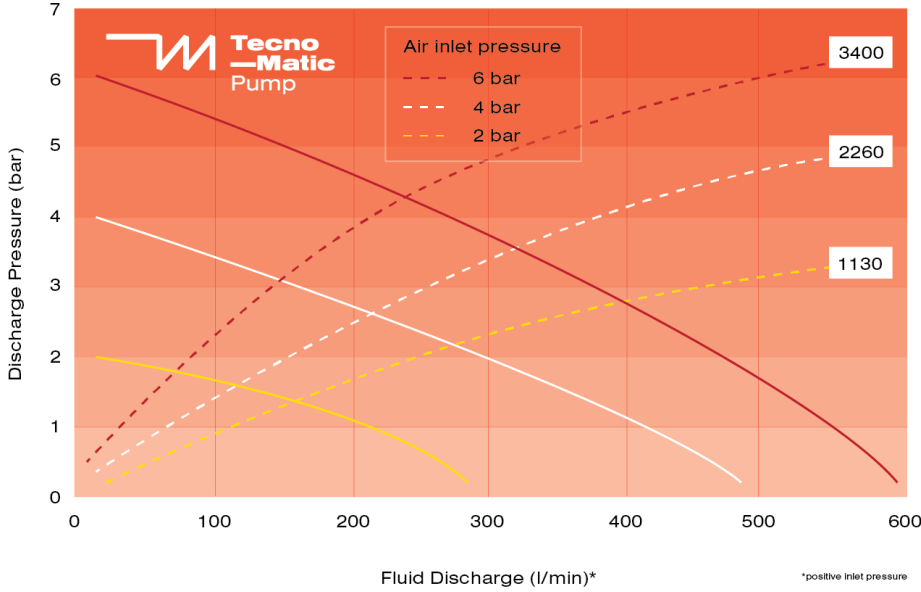

Air Consumption (NI/min)

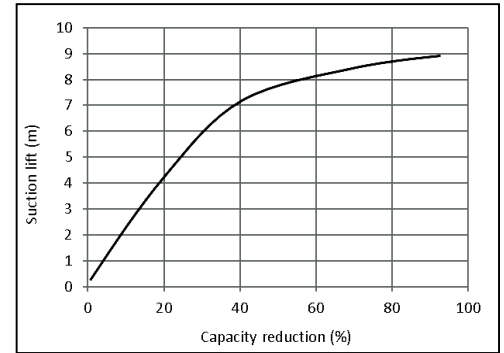

### Available types

Type
TM3-530/2"-S-ST-ST
TM3-530/2"-S-NBR-NBR
TM3-530/2"-S-T-T

Max. weight: 70 Kg

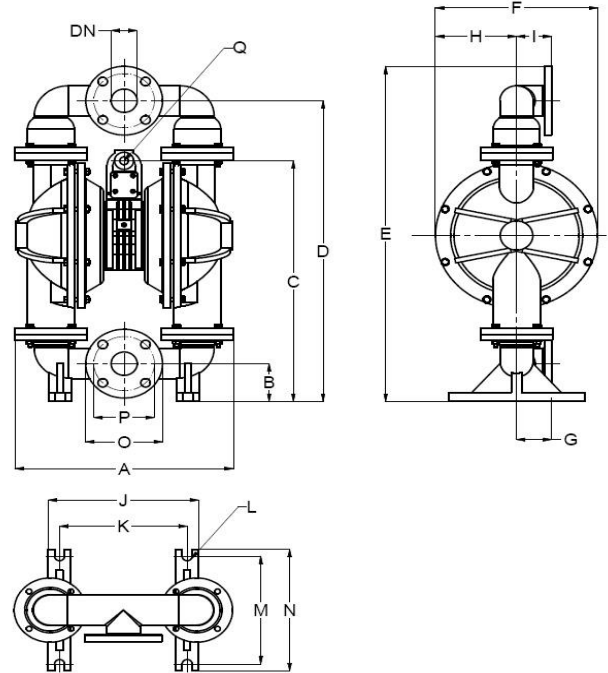

<b>A</b>	435 mm	<b>G</b>	70 mm	<b>M</b>	240 mm
<b>B</b>	84 mm	<b>H</b>	162 mm	<b>N</b>	270 mm
<b>C</b>	535 mm	<b>I</b>	70 mm	<b>Q</b>	½" female
<b>D</b>	669 mm	<b>J</b>	299 mm	<b>O</b>	153 mm
<b>E</b>	746 mm	<b>K</b>	254 mm	<b>P</b>	121 mm
<b>F</b>	323 mm	<b>L</b>	20 mm	<b>DN</b>	52 mm