

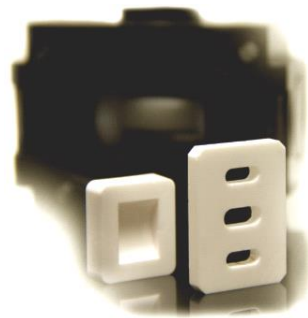

- Capacity 1 – 50 l/min
- 1/2" connection in several positions
- Ceramic air-valve system
- Max. sizes solid parts in liquid 1,5 mm
- Viscosity up to 30 000 cP
- Low noise (72 dBa)
- Pump body: PP
- Low air-consumption
- Dry running capability
- Low maintenance and parts costs
- Bolted (SST) leakage free design
- No Air leakage at liquid stop



**Each pump tested
Test report included**



**Maintenance Free
Ceramic Air-Valve Parts**

APPLICATIONS

CHEMICALS • SOLVENTS • PLATING • ACIDS • OILS • INKS • GLUES • ALKALIES • ENAMEL
POLYESTER PAINT • WASTE WATER • COOLING LIQUIDS • FOAMS • HYDRAULIC OILS

Flowchart 1/2" Series

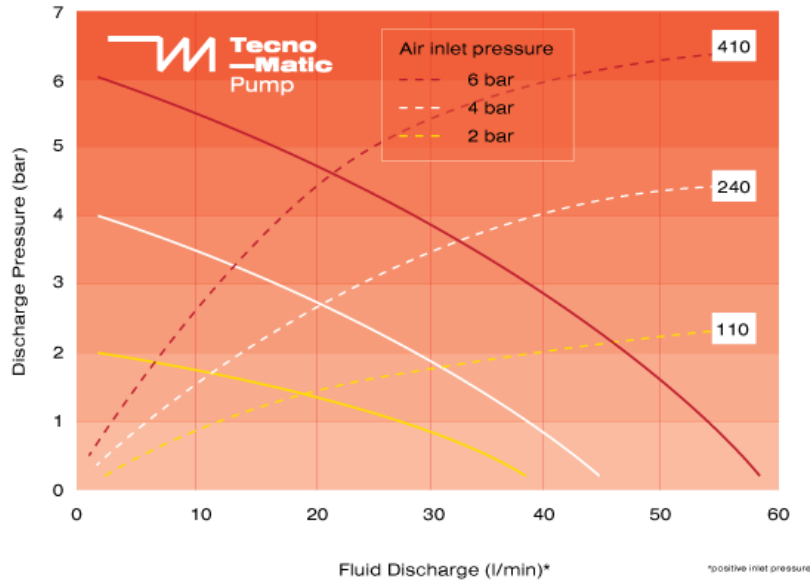

Air Consumption (NI/min)

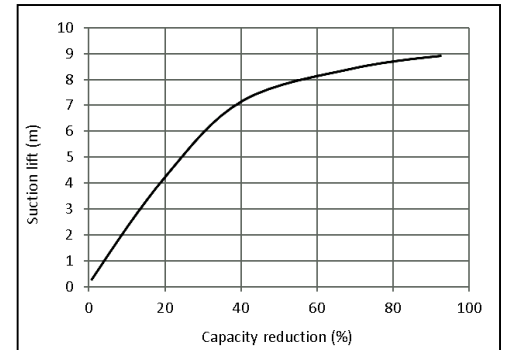
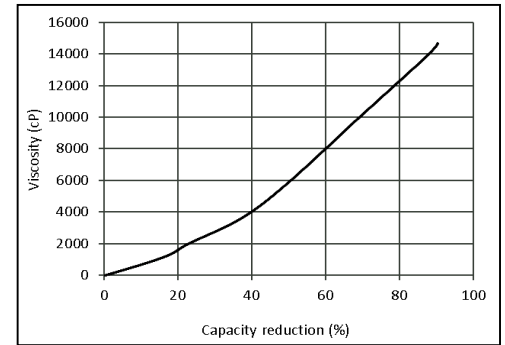

Available types

Type
TM3-50/0.5"-P-ST-ST
TM3-50/0.5"-P-NBR-NBR
TM3-50/0.5"-P-T-T

Max. weight: 4 Kg

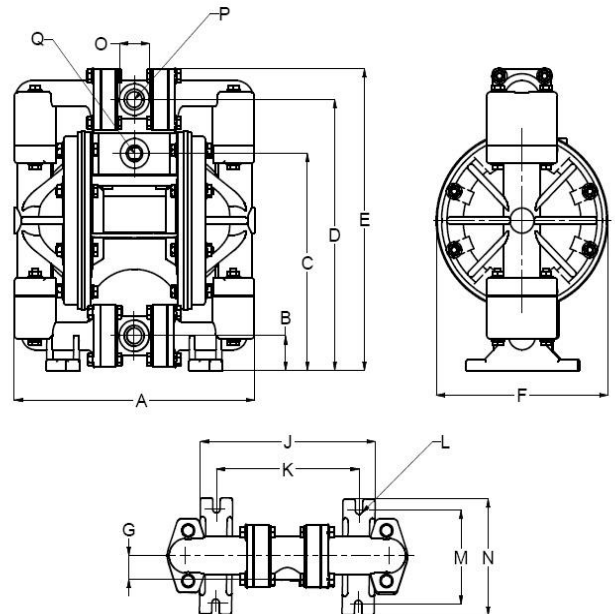

A	224 mm	G	21 mm	O	28 mm
B	31 mm	J	163 mm	P	1/2" female
C	194 mm	K	133 mm	Q	3/8" female
D	242 mm	L	7 mm		
E	270 mm	M	84 mm		
F	160 mm	N	104 mm		