

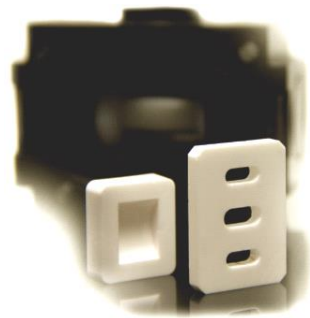

- Capacity 5 – 130 l/min
- 1" connection in several positions
- Standard equipped with Santoprene
- Ceramic air-valve system
- Max. sizes solid parts in liquid 3 mm
- Viscosity up to 30 000 cP
- Low noise (77 dBA)
- Pump body: PP
- Low air-consumption !
- Dry running capability
- Low maintenance and parts costs
- Bolted (SST) leakage free design
- No Air leakage at liquid stop



**Each pump tested
Test report included**



**Maintenance Free
Ceramic Air-Valve Parts**

APPLICATIONS

CHEMICALS • SOLVENTS • PLATING • ACIDS • OILS • INKS • GLUES • ALKALIES • ENAMEL
POLYESTER PAINT • WASTE WATER • COOLING LIQUIDS • FOAMS • HYDRAULIC OILS

Flowchart 3/4" Series

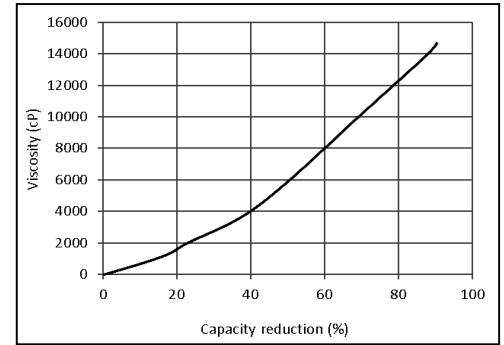
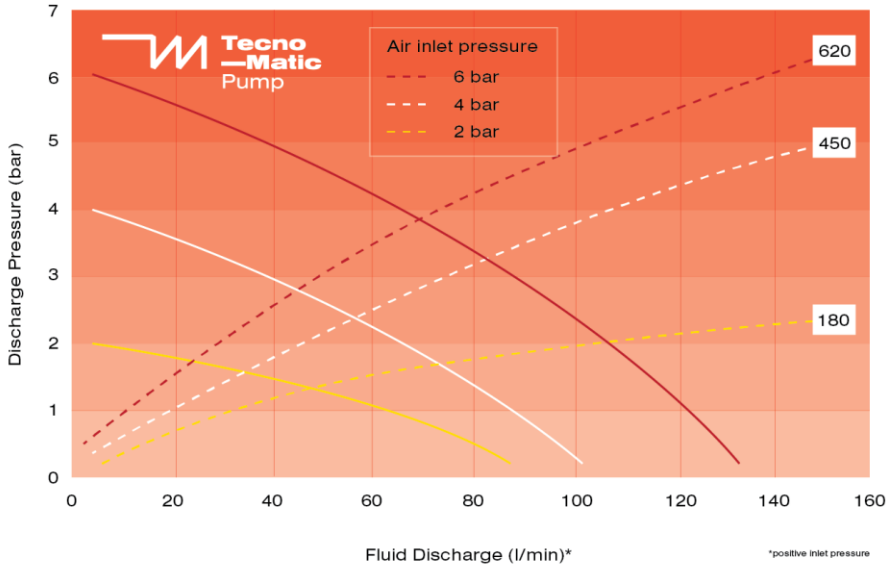

Air Consumption (Nl/min)

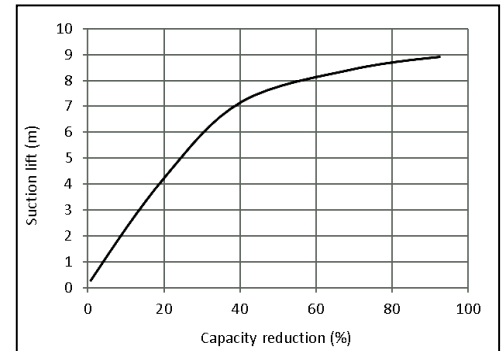

Available types

Type
TM3-100/0.75"-P-ST-ST
TM3-100/0.75"-P-NBR-NBR
TM3-100/0.75"-P-T-T

Max. weight: 9 Kg

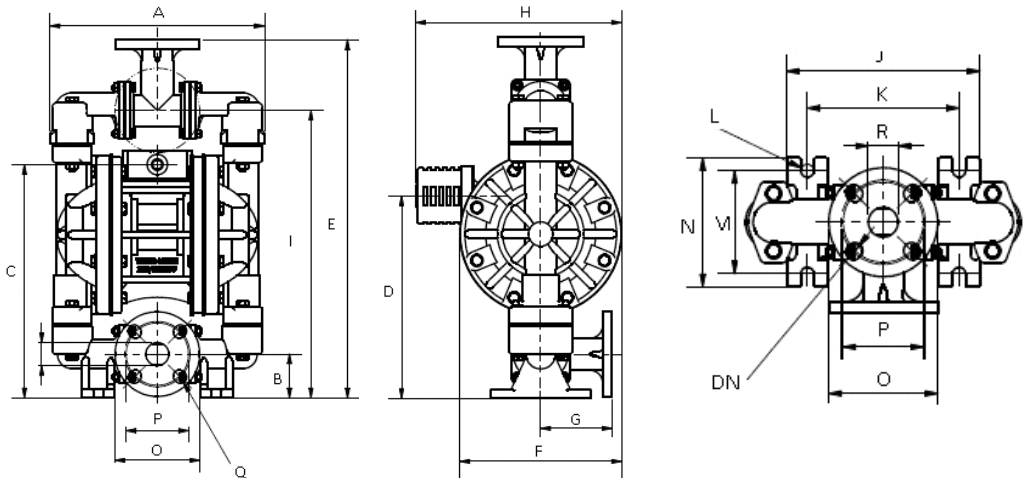

A	279 mm	G	92 mm	M	104 mm
B	57 mm	H	13 mm	N	130 mm
C	329 mm	I	92 mm	Q	3/8" female
D	374 mm	J	194 mm	O	110 mm
E	429 mm	K	154 mm	P	82-85 mm
F	209 mm	L	13 mm	DN	30 mm