

- Capacity 5 – 150 l/min
- 1" connections
- PTFE, NBR or Santoprene diaphragms
- Pump body: HDPE, PP, PTFE
- Ceramic air-valve system
- ATEX version up on request
- Max. sizes solid parts in liquid 3 mm
- Viscosity up to 30 000 cP
- Low noise (77 dBA)
- Low air-consumption
- Dry running capability
- Low maintenance and parts costs
- Bolted (SST) leakage free design
- No air leakage at liquid stop



**Each pump tested
Test report included**



ATEX Version up on request

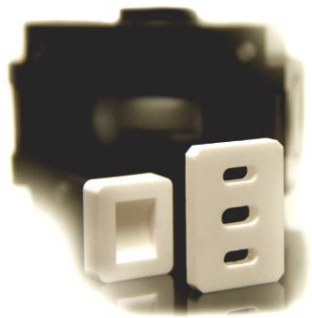

**Maintenance Free
Ceramic Air-Valve Parts**

APPLICATIONS

CHEMICALS • SOLVENTS • PLATING • ACIDS • OILS • INKS • GLUES • ALKALIES • ENAMEL
POLYESTER PAINT • WASTE WATER • COOLING LIQUIDS • FOAMS • HYDRAULIC OILS

Flowchart 1" Series

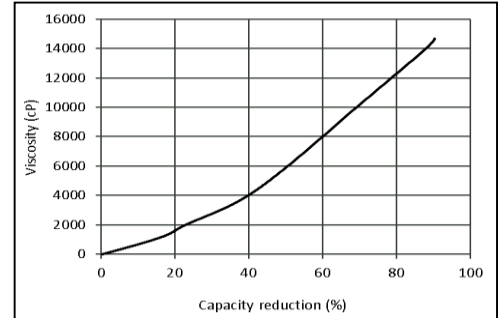
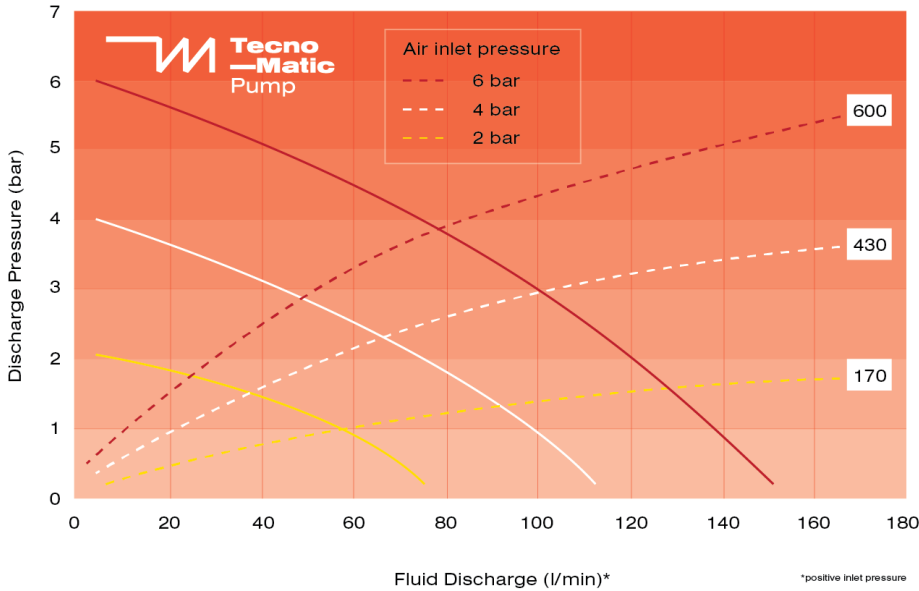

Air Consumption (NI/min)

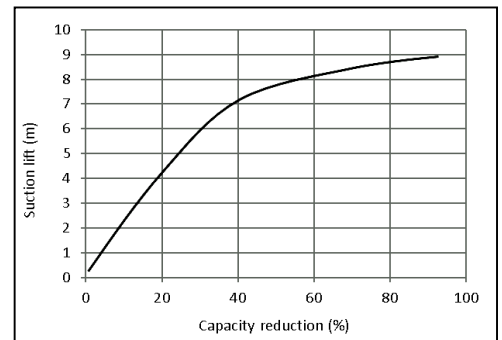

Available types

Type
TM2-150/1"-HDPE-ST-ST
TM2-150/1"-HDPE-NBR-NBR
TM2-150/1"-HDPE-T-T
TM2-150/1"-P-ST-ST
TM2-150/1"-P-NBR-NBR
TM2-150/1"-P-T-T
TM2-150/1"-PTFE-ST-ST
TM2-150/1"-PTFE-NBR-NBR
TM2-150/1"-PTFE-T-T

Max. weight: 14 Kg

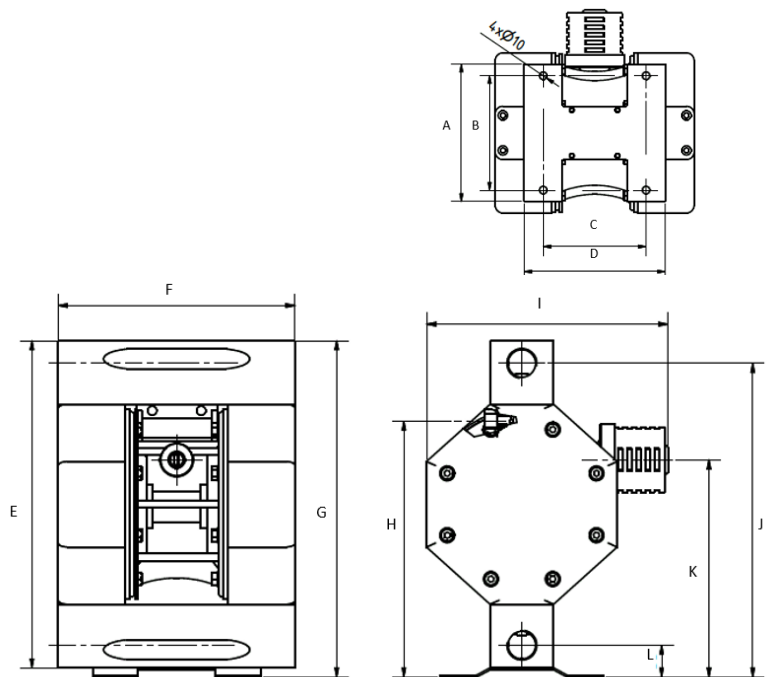

A	180 mm	E	360 mm	I	266 mm
B	150 mm	F	261 mm	J	345 mm 1"
C	135 mm	G	370 mm	K	239 mm
D	185 mm	H	282 mm	L	30 mm 1"